



HIGH PRECISION PLANETARY GEAR BOX



HYE/HYF/HYWE/HYWF/HYS Series



Sectional Drawing

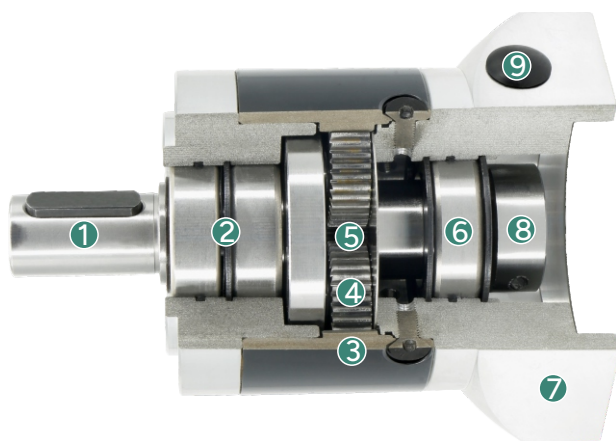

- ① Output shaft
- ② Bearing for the output shaft
- ③ Internal gear
- ④ Planetary gear
- ⑤ Sunwheel
- ⑥ Bearing for the sunwheel
- ⑦ Appropriate motor flange
- ⑧ Precision clamping system
- ⑨ Mounting hole

Type And Model Number

HY Series Gear Head	Servo Motor																																				
80 HYE 20 () (S) -750 T1 ① ② ③ ④ ⑤ ⑥ ⑦																																					
① Gear head frame size:80																																					
② Gear head series code: HYE: Roud mounting flange series HYWE: Right angle input roud mounting flange series HYF: Square mounting flange series HYWF: Right angle input square mounting flange series HYS: Hight stiffness series																																					
③ Gear Ratio: Single Stage 3,4,5,8,10 Two Stage 9,12,15,16,20,25,32,40,64 Three Stage 60,80,100,120,160,200,256,320,512																																					
④ Amount of backlash Precision (The load of output shaft is ±3% of allowable output torque)	<table border="1" style="width: 100%; border-collapse: collapse;"> <thead> <tr style="background-color: #e0f2f1;"> <th>Reducer Type No.</th> <th>Stage</th> <th>Standard Type</th> </tr> </thead> <tbody> <tr> <td rowspan="3" style="text-align: center;">40HYE/F</td> <td style="text-align: center;">1</td> <td style="text-align: center;">12分arc-min</td> </tr> <tr> <td style="text-align: center;">2</td> <td style="text-align: center;">15分arc-min</td> </tr> <tr> <td style="text-align: center;">3</td> <td style="text-align: center;">18分arc-min</td> </tr> <tr> <td rowspan="3" style="text-align: center;">60HYE/F 80HYE/F 120HYE/F 160HYE/F</td> <td style="text-align: center;">1</td> <td style="text-align: center;">8分arc-min</td> </tr> <tr> <td style="text-align: center;">2</td> <td style="text-align: center;">12分arc-min</td> </tr> <tr> <td style="text-align: center;">3</td> <td style="text-align: center;">15分arc-min</td> </tr> <tr> <td rowspan="2" style="text-align: center;">115HYS 142HYS 190HYS</td> <td style="text-align: center;">1</td> <td style="text-align: center;">8分arc-min</td> </tr> <tr> <td style="text-align: center;">2</td> <td style="text-align: center;">12分arc-min</td> </tr> <tr> <td rowspan="3" style="text-align: center;">60HYWE/F</td> <td style="text-align: center;">1</td> <td style="text-align: center;">30分arc-min</td> </tr> <tr> <td style="text-align: center;">2</td> <td style="text-align: center;">35分arc-min</td> </tr> <tr> <td style="text-align: center;">3</td> <td style="text-align: center;">40分arc-min</td> </tr> <tr> <td rowspan="3" style="text-align: center;">80HYWE/F 120HYWE/F 160HYWE/F</td> <td style="text-align: center;">1</td> <td style="text-align: center;">25分arc-min</td> </tr> <tr> <td style="text-align: center;">2</td> <td style="text-align: center;">30分arc-min</td> </tr> <tr> <td style="text-align: center;">3</td> <td style="text-align: center;">35分arc-min</td> </tr> </tbody> </table>	Reducer Type No.	Stage	Standard Type	40HYE/F	1	12分arc-min	2	15分arc-min	3	18分arc-min	60HYE/F 80HYE/F 120HYE/F 160HYE/F	1	8分arc-min	2	12分arc-min	3	15分arc-min	115HYS 142HYS 190HYS	1	8分arc-min	2	12分arc-min	60HYWE/F	1	30分arc-min	2	35分arc-min	3	40分arc-min	80HYWE/F 120HYWE/F 160HYWE/F	1	25分arc-min	2	30分arc-min	3	35分arc-min
Reducer Type No.	Stage	Standard Type																																			
40HYE/F	1	12分arc-min																																			
	2	15分arc-min																																			
	3	18分arc-min																																			
60HYE/F 80HYE/F 120HYE/F 160HYE/F	1	8分arc-min																																			
	2	12分arc-min																																			
	3	15分arc-min																																			
115HYS 142HYS 190HYS	1	8分arc-min																																			
	2	12分arc-min																																			
60HYWE/F	1	30分arc-min																																			
	2	35分arc-min																																			
	3	40分arc-min																																			
80HYWE/F 120HYWE/F 160HYWE/F	1	25分arc-min																																			
	2	30分arc-min																																			
	3	35分arc-min																																			
⑤ Input shaft type S: Over locking (Omission) (Can use it whatever motor shaft has keyway or not) S1: Locking with locking ring (Can use it whatever motor shaft has keyway or not) S2: Locking with keyway (Input shaft with key) K: With keyway A: Other type (Please contact with us)																																					
⑥ Applicable servo motor power (W)																																					
⑦ Input flange and servo motor matching table (P15)																																					

HYE/HYF SERIES PRECISION PLANETARY GEAR MOTOR

Product Graph

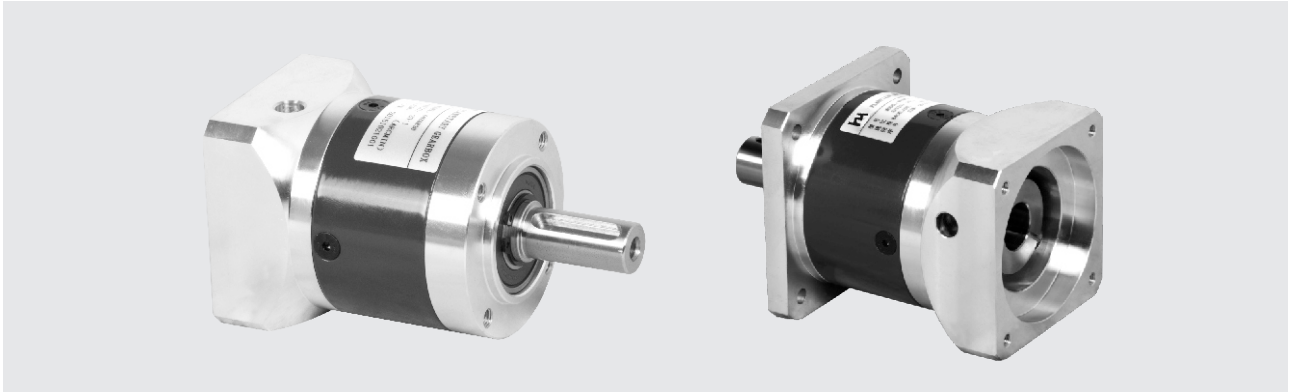

Technical Data

Product type		40	60	80	120	160	Reduction ratio	Number of stage
Rated output torque	N.M	4.5	12	40	80	400	3	1
		6	16	50	110	450	4	
		6	16	50	110	450	5	
		5	15	45	100	400	8	
		4	12	40	80	305	10	
		/	40	100	210	/	9	2
		16.5	40	100	210	700	12	
		16.5	40	100	210	700	15	
		20	44	120	260	800	16	
		20	44	120	260	800	20	
		18	40	110	230	700	25	
		20	44	120	260	800	32	
		18	40	110	230	700	40	
		7.5	18	45	100	400	64	
		16.5	40	100	210	/	60	
		20	44	120	260	/	80	
		20	44	120	260	/	100	
		16.5	40	100	210	/	120	
		20	44	120	260	/	160	
		18	40	110	230	/	200	
20	44	120	260	/	256			
18	40	110	230	/	320			
7.5	18	45	100	/	512			
Life	Hour	20,000						
Instant stop torque	N.M	Two times of rated output torque						
Product type		40	60	80	120	160	Unit	Number of stage
Max radial load		160	450	900	2100	6000	N	
Max axial load		80	225	450	1050	3000	N	
Full load efficiency		96					%	1
		94						2
		90						3
Weight		0.4	0.9	2.1	6	18	Kg	1
		0.5	1.1	2.6	8	22		2
		0.6	1.3	3.1	9.5	/		3
Operating temperature		-25~+90					°C	
IP		Ip54						
Lubrication type		Lifetime lubrication						
Mounting type		Any						

* The max radial and load torque work in the location of the center of output shaft when the out speed is 100RPM.

HYE/HYF SERIES PRECISION PLANETARY GEAR MOTOR

Technical Data

Product type		40	60	80	120	160	Reduction ratio
Moment of inertia	Kgcm ²	0.031	0.135	0.77	2.63	12.14	3
		0.022	0.093	0.52	1.79	7.78	4
		0.019	0.078	0.45	1.53	6.07	5
		0.017	0.065	0.39	1.32	4.63	8
		0.015	0.054	0.34	1.14	3.52	10
		/	0.131	0.74	2.62	/	9
		0.022	0.088	0.50	2.56	7.47	12
		0.019	0.077	0.44	1.79	6.65	15
		0.022	0.088	0.50	1.75	7.47	16
		0.019	0.075	0.44	1.50	6.65	20
		0.019	0.075	0.44	1.49	5.81	25
		0.017	0.064	0.39	1.30	4.50	32
		0.016	0.064	0.39	1.30	4.50	40
		0.016	0.064	0.39	1.30	4.50	64
		0.019	0.075	0.50	1.50	/	60
		0.019	0.075	0.50	1.50	/	80
		0.019	0.075	0.44	1.49	/	100
		0.016	0.064	0.39	1.30	/	120
		0.016	0.064	0.39	1.30	/	160
0.016	0.064	0.39	1.30	/	200		
0.016	0.064	0.39	1.30	/	256		
0.016	0.064	0.39	1.30	/	320		
0.016	0.064	0.39	1.30	/	512		

Product type		40	60	80	120	160	Number of stage
Backlash	arcmin	< 12	< 8	< 8	< 8	< 8	1
		< 15	< 12	< 12	< 12	< 12	2
		< 18	< 15	< 15	< 15	/	3

Product type		40	60	80	120	160	
Torsional stiffness	N.M/arcmin	0.7	1.8	4.5	12	38	
Noise	dB(A)	55	58	60	65	70	
Max input speed	min ⁻¹	4500	4500	4500	4500	4500	
Recommend input speed	min ⁻¹	3000	3000	3000	3000	3000	

1. The moment of inertia is related with input shaft.
2. Noise test standard, distance 1m, measured on no-load running with an input speed of 3000rpm.

HYE SERIES PRECISION PLANETARY GEAR MOTOR

Dimensions

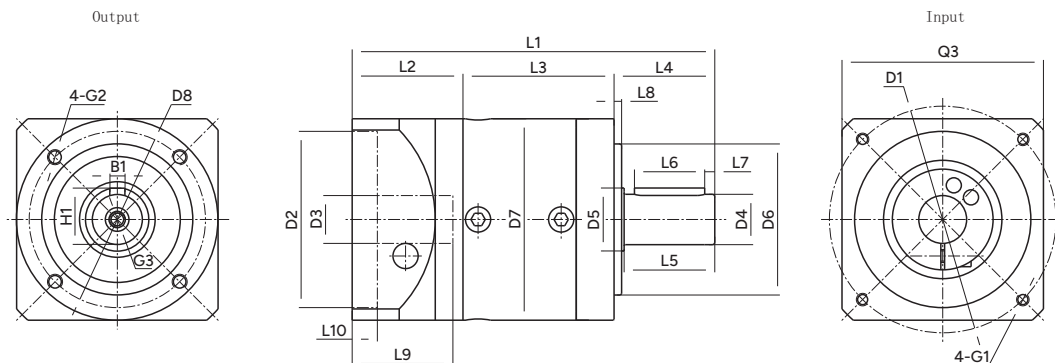

Unit: mm

Product type	40HYE			60HYE			80HYE			120HYE			160HYE	
Number of stage	1	2	3	1	2	3	1	2	3	1	2	3	1	2
L1 overall length	93.5	106.5	119	114	127	140	144	162	179.5	195.2	223	250.5	302	345.5
L3 body length	39	52	64.5	46.5	59.5	72.5	60	78	95.5	73.7	101.5	129	116	159.5
Output														
L4 output shaft length	26			35			40			55			87	
L5 output length to the shaft shoulder	23			30.5			36			50			80	
L6 key length	16			25			28			40			70	
L7 key length to the shaft end	3.5			2.5			4			5			5	
L8 protruding length	2			3			3			4			5	
D4 output shaft diameter	Φ10h7			Φ14h7			Φ20h7			Φ25h7			Φ40h7	
D5 shaft shoulder diameter	Φ12			Φ17			Φ25			Φ35			Φ55	
D6 protruding diameter	Φ26h7			Φ40h7			Φ60h7			Φ80h7			Φ130h7	
D7 body diameter	Φ40			Φ60			Φ80			Φ115			Φ160	
D8 hole circle	Φ34			Φ52			Φ70			Φ100			Φ145	
B1 key width	3			5			6			8			12	
H1 key height	11.2			16			22.5			28			43	
G2 mounting screw hole	M4x6			M5x8			M6x10			M10x16			M12x20	
G3 center screw hole	M3x9			M5x12			M6x16			M10x22			M12x25	
Input														
L2 input flange length	28.5			32			44			66.5			99	
L9 motor shaft length	26			30			40			58			79	
L10 protruding depth	6			10			10			10			10	
D1 mounting hole distribution circle	Φ46			Φ70			Φ90			Φ145			Φ200	
D2 protruding diameter	Φ30G7			Φ50G7			Φ70G7			Φ110G7			Φ114.3G7	
D3 input shaft diameter	≤Φ8G7			≤Φ14G7			≤Φ19G7			≤Φ24G7			≤Φ35G7	
G1 mounting threads hole x depth	M4x10			M5x12			M6x15			M8x22			M12x25	
Q3 input flange	□40			□60			□80			□130			□175	

※Input size made according to motor size.

HYF SERIES PRECISION PLANETARY GEAR MOTOR

Dimensions

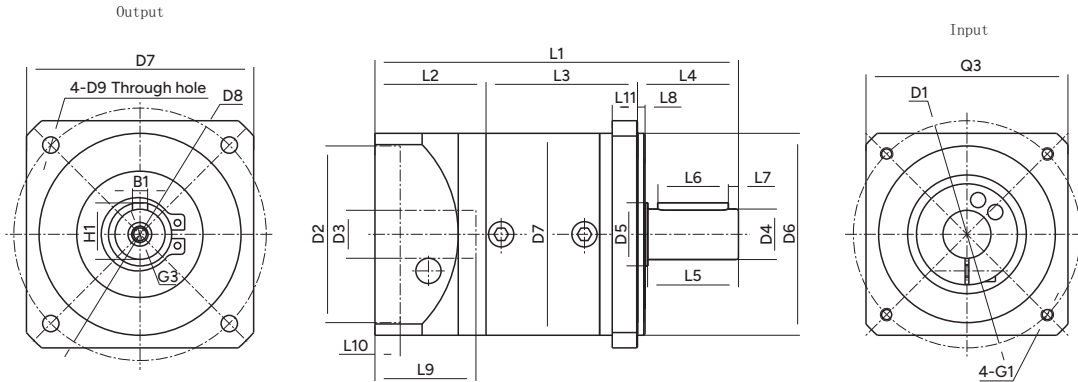

Unit: mm

Product type	40HYF			60HYF			80HYF			120HYF			160HYF	
Number of stage	1	2	3	1	2	3	1	2	3	1	2	3	1	2
L1 overall length	93.5	106.5	119	114	127	140	144	162	179.5	195.2	223	250.5	302	345.5
L3 body length	39	52	64.5	46.5	59.5	72.5	60	78	95.5	73.7	101.5	129	116	159.5
Output														
L4 output shaft length	26			35			40			55			87	
L5 output length to the shaft shoulder	23			30.5			36			50			80	
L6 key length	16			25			28			40			70	
L7 key length to the shaft end	3.5			2.5			4			5			5	
L8 protruding length	2			3			3			4			5	
L11 output flange thickness	6			8			10			15			15	
D4 output shaft diameter	Φ10h7			Φ14h7			Φ20h7			Φ25h7			Φ40h7	
D5 shaft shoulder diameter	Φ12			Φ17			Φ25			Φ35			Φ55	
D6 protruding diameter	Φ26h7			Φ50h7			Φ80h7			Φ110h7			Φ130h7	
D7 output flange	□45			□60			□90			□120			□160/□175	
D8 hole circle	Φ50			Φ70			Φ100			Φ130			Φ185/Φ200	
D9 mounting hole	Φ3.5			Φ5.5			Φ6.5			Φ8.5			Φ11/Φ13.5	
B1 key width	3			5			6			8			12	
H1 key height	11.2			16			22.5			28			43	
G3 center screw hole	M3x9			M5x12			M6x16			M10x22			M12x25	
Input														
L2 input flange length	28.5			32			44			66.5			99	
L9 motor shaft length	26			30			40			58			79	
L10 protruding depth	6			10			10			10			10	
D1 mounting hole distribution circle	Φ46			Φ70			Φ90			Φ145			Φ200	
D2 protruding diameter	Φ30G7			Φ50G7			Φ70G7			Φ110G7			Φ114.3G7	
D3 input shaft diameter	≤Φ8G7			≤Φ14G7			≤Φ19G7			≤Φ24G7			≤Φ35G7	
G1 mounting threads hole x depth	M4x10			M5x12			M6x15			M8x22			M12x25	
Q3 input flange	□40			□60			□80			□130			□175	

※Input size made according to motor size.

HYWE/HYWF SERIES PRECISION PLANETARY GEAR MOTOR

Product Graph

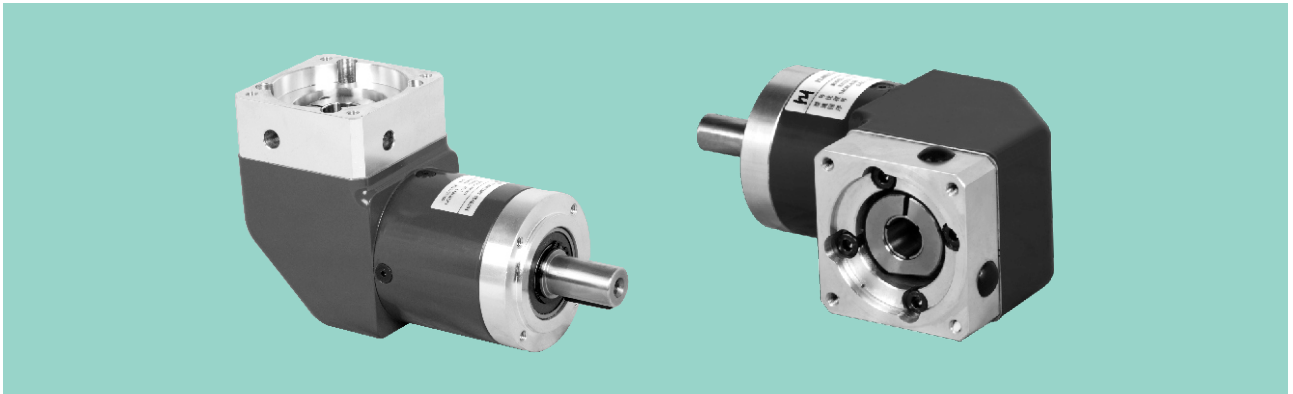

Technical Data

Product type		60	80	120	160	Reduction ratio	Number of stage
Rated output torque	N.M	12	40	80	400	3	1
		16	50	110	450	4	
		16	50	110	450	5	
		15	45	100	400	8	
		12	40	80	305	10	
		40	100	210	/	9	2
		40	100	210	700	12	
		40	100	210	700	15	
		44	120	260	800	16	
		44	120	260	800	20	
		40	110	230	700	25	3
		44	120	260	800	32	
		40	110	230	700	40	
		18	45	100	400	64	
		40	100	210	/	60	
		44	120	260	/	80	3
		44	120	260	/	100	
		40	100	210	/	120	
		44	120	260	/	160	
		40	110	230	/	200	
44	120	260	/	256	3		
40	110	230	/	320			
18	45	100	/	512			
Life	Hour	20,000					
Instant stop torque	N.M	Two times of rated output torque					
Product type		60	80	120	160	Unit	Number of stage
Max radial load		450	900	2100	6000	N	
Max axial load		225	450	1050	3000	N	
Full load efficiency		94				%	1
		92					2
		88					3
Weight		1.7	4.4	12	36	Kg	1
		1.9	5	14	40		2
		2.1	5.5	16	/		3
Operating temperature		-25~+90				°C	
IP		Ip54					
Lubrication type		Lifetime lubrication					
Mounting type		Any					

The max radial and axial load work in the location of the center of output shaft when the out speed is 100RPM.

HYWE/HYWF SERIES PRECISION PLANETARY GEAR MOTOR

Technical Data

Product type		60	80	120	160	Reduction ratio
Moment of inertia	Kgcm ²	0.246	1.189	5.75	24.5	3
		0.204	0.939	3.91	19.4	4
		0.189	0.869	3.35	17.5	5
		0.176	0.809	2.89	15.9	8
		0.152	0.730	2.54	15.5	10
		0.242	1.159	5.73	/	9
		0.199	0.919	3.83	/	12
		0.188	0.859	3.28	17.5	15
		0.199	0.919	3.83	19.4	16
		0.186	0.859	3.28	17.5	20
		0.186	0.859	3.26	17.5	25
		0.175	0.809	2.84	15.9	32
		0.175	0.809	2.84	15.9	40
		0.175	0.809	2.84	15.9	64
		0.186	0.919	3.28	/	60
		0.186	0.919	3.28	/	80
		0.186	0.859	3.26	/	100
		0.175	0.809	2.84	/	120
		0.175	0.809	2.84	/	160
		0.175	0.809	2.84	/	200
0.175	0.809	2.84	/	256		
0.175	0.809	2.84	/	320		
0.175	0.809	2.84	/	512		

Product type		60	80	120	160	Number of stage
Backlash	arcmin	< 30	< 25	< 25	< 25	1
		< 35	< 30	< 30	< 30	2
		< 40	< 35	< 35	/	3
Torsional stiffness	N.M/arcmin	1.5	4.5	10	38	1
		2.5	6.5	13	43	2
		2.5	6.3	12	/	3
Noise	dB(A)	65	68	70	70	
Max input speed	min ⁻¹	4500	4500	4500	4500	
Recommend input speed	min ⁻¹	3000	3000	3000	3000	

1. The moment of inertia is related with input shaft.

2. Noise test standard, distance 1m, measured on no-load running with an input speed of 3000rpm.

HYWE SERIES PRECISION PLANETARY GEAR MOTOR

Dimensions

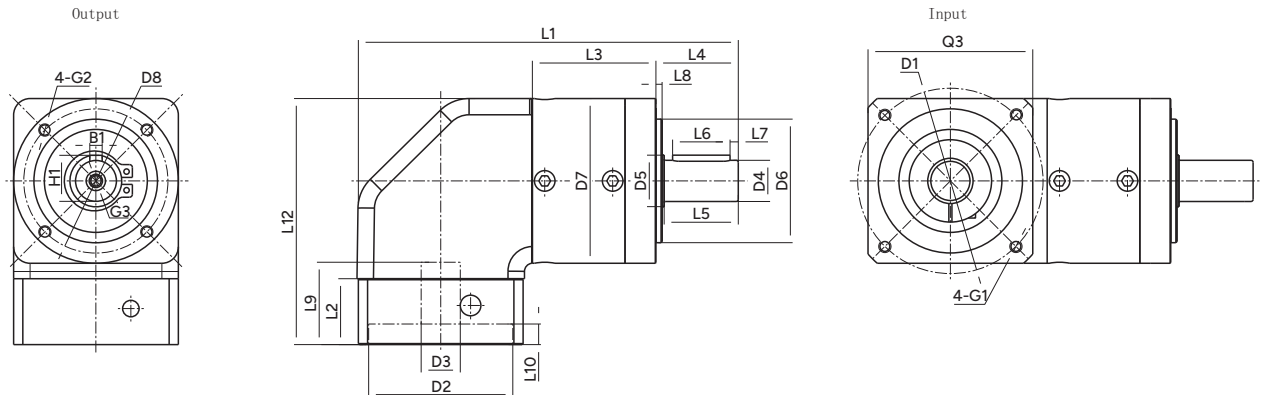

Unit: mm

Product type	60HYWE			80HYWE			120HYWE			160HYWE	
Number of stage	1	2	3	1	2	3	1	2	3	1	2
L1 overall length	150	163	176	184.5	202.5	220	249.2	277	304.5	380	423.5
L3 body length	46.5	59.5	72.5	60	78	95.5	73.7	101.5	129	141	184.5
L12 overall heights	93			119.5			167.5			229	
Output											
L4 output shaft length	35			40			55			87	
L5 output length to the shaft shoulder	30.5			36			50			80	
L6 key length	25			28			40			70	
L7 key length to the shaft end	2.5			4			5			5	
L8 protruding length	3			3			4			5	
D4 output shaft diameter	Φ14h7			Φ20h7			Φ25h7			Φ40h7	
D5 shaft shoulder diameter	Φ17			Φ25			Φ35			Φ55	
D6 protruding diameter	Φ40h7			Φ60h7			Φ80h7			Φ130h7	
D7 body diameter	Φ60			Φ80			Φ115			Φ160	
D8 hole circle	Φ52			Φ70			Φ100			Φ145	
B1 key width	5			6			8			12	
H1 key height	16			22.5			28			43	
G2 mounting thread hole x depth	M5x8			M6x10			M10x16			M12x20	
G3 center screw hole	M5x12			M6x16			M10x22			M12x25	
Input											
L2 input flange length	20			32			38			66	
L9 motor shaft length	30			40			58			81	
L10 protruding depth	5			10			10			10	
D1 mounting hole distribution circle	Φ70			Φ90			Φ145			Φ200	
D2 protruding diameter	Φ50G7			Φ70G7			Φ110G7			Φ114.3G7	
D3 input shaft diameter	≤Φ14G7			≤Φ19G7			≤Φ24G7			≤Φ35G7	
G1 mounting threads hole x depth	M5x12			M6x15			M8x22			M12x25	
Q3 input flange	□60			□80			□130			□175	

※Input size made according to motor size.

HYWF SERIES PRECISION PLANETARY GEAR MOTOR

Dimensions

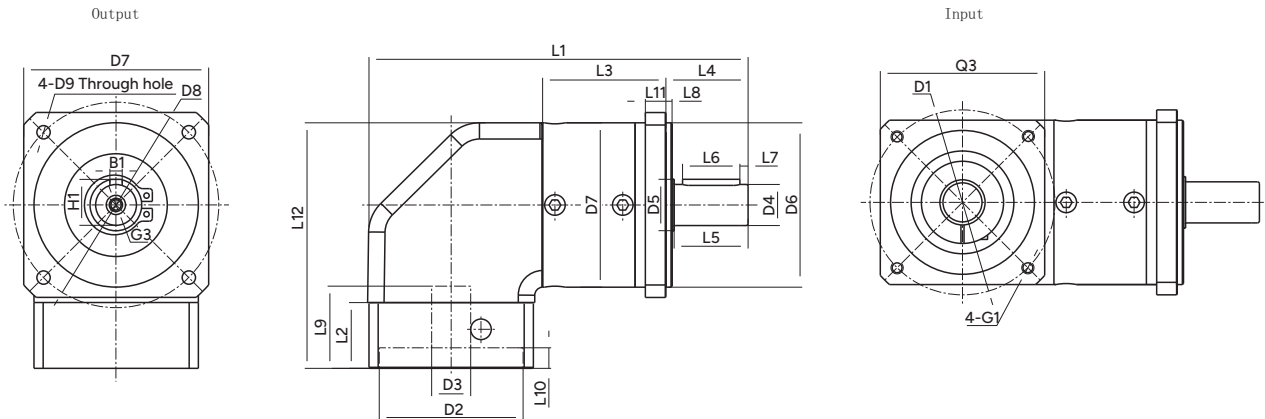

Unit: mm

Product type	60HYWF			80HYWF			120HYWF			160HYWF	
Number of stage	1	2	3	1	2	3	1	2	3	1	2
L1 overall length	150	163	176	184.5	202.5	220	249.2	277	304.5	380	423.5
L3 body length	46.5	59.5	72.5	60	78	95.5	73.7	101.5	129	141	184.5
L12 overall heights	93			119.5			167.5			229	
Output											
L4 output shaft length	35			40			55			87	
L5 output length to the shaft shoulder	30.5			36			50			80	
L6 key length	25			28			40			70	
L7 key length to the shaft end	2.5			4			5			5	
L8 protruding length	3			3			4			5	
L11 flange thickness	8			10			15			15	
D4 output shaft diameter	Φ14h7			Φ20h7			Φ25h7			Φ40h7	
D5 shaft shoulder diameter	Φ17			Φ25			Φ35			Φ55	
D6 protruding diameter	Φ50h7			Φ80h7			Φ110h7			Φ130h7	
D7 body diameter	□60			□90			□120			□160/□175	
D8 hole circle	Φ70			Φ100			Φ130			Φ185/Φ200	
D9 mounting bore	Φ5.5			Φ6.5			Φ8.5			Φ11/Φ13.5	
B1 key width	5			6			8			12	
H1 key height	16			22.5			28			43	
G3 center screw hole	M5x12			M6x16			M10x22			M12x25	
Input											
L2 input flange length	20			32			38			66	
L9 motor shaft length	30			40			58			81	
L10 protruding depth	5			10			10			10	
D1 mounting hole distribution circle	Φ70			Φ90			Φ145			Φ200	
D2 protruding diameter	Φ50G7			Φ70G7			Φ110G7			Φ114.3G7	
D3 input shaft diameter	≤Φ14G7			≤Φ19G7			≤Φ24G7			≤Φ35G7	
G1 mounting threads hole x depth	M5x12			M6x15			M8x22			M12x25	
Q3 input flange	□60			□80			□130			□175	

※Input size made according to motor size.

HYS SERIES PRECISION PLANETARY GEAR MOTOR

Product Graph

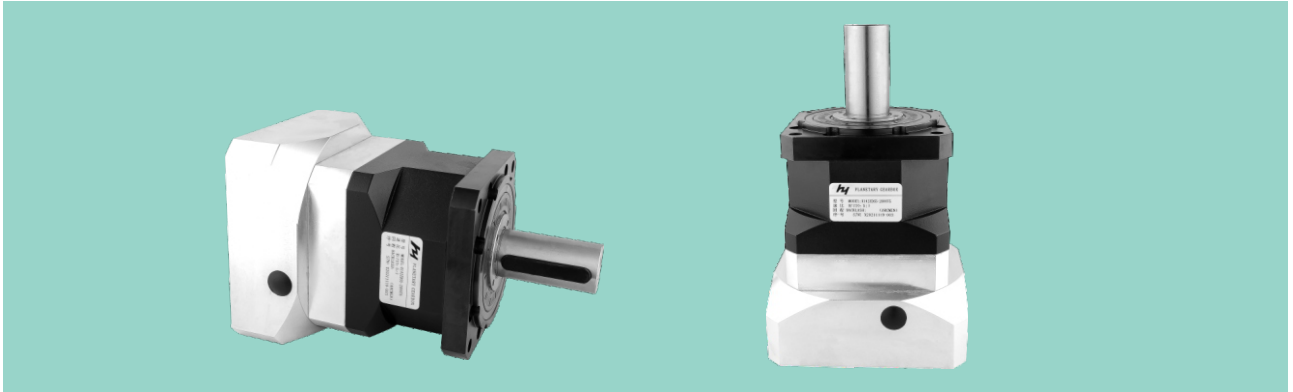

Technical Data

Product type		115	142	190	Reduction ratio	Number of stage
Rated output torque	N.M	150	400	1000	3	1
		200	560	1200	4	
		210	700	1600	5	
		148	450	1000	8	
		125	305	630	10	
		210	780	1500	12	2
		210	780	1500	15	
		260	910	1800	16	
		260	910	1800	20	
		210	780	1800	25	
		260	910	1800	32	
		210	780	1800	40	
		148	450	1000	64	
		125	305	630	100	
Life	Hour	20,000				
Instant stop torque	N.M	Two times of rated output torque				

Product type	115	142	190	Unit	Number of stage
Max radial load	4300	8200	12000	N	
Max axial load	12000	19000	28000	N	
Full load efficiency	96			%	1
	94				2
Weight	9	15.4	33.5	Kg	1
	11.6	18.5	45		2
Operating temperature	-25~+90			°C	
IP	Ip65				
Lubrication type	Lifetime lubrication				
Mounting type	Any				

The max radial and axial load work in the location of the center of output shaft when the out speed is 100RPM.

HYS SERIES PRECISION PLANETARY GEAR MOTOR

Technical Data

Product type		115	142	190	Reduction ratio
Moment of inertia	kgcm ²	2.10	12.14	47.52	3
		1.51	7.78	29.69	4
		1.22	6.07	23.18	5
		1.05	4.63	16.83	8
		1.00	4.25	15.32	10
		1.48	7.47	28.95	12
		1.41	6.65	22.71	15
		1.48	7.47	28.95	16
		1.41	6.65	22.71	20
		1.21	5.81	22.46	25
		1.46	6.36	16.65	32
		1.05	5.28	16.54	40
		1.05	4.50	16.45	64
		1.00	4.17	15.07	100

Product type		115	142	190	Number of stage
Backlash	arcmin	< 8	< 8	< 8	1
		< 12	< 12	< 12	2
Torsional stiffness	N.M/arcmin	20	44	130	1
		22	46	140	2
Noise	dB(A)	65	68	70	
Max input speed	min ⁻¹	4500	4500	3000	
Recommend input speed	min ⁻¹	3000	3000	2000	

1.The moment of inertia is related with input shaft.

2. Noise test standar, distance 1m, measured on no-load running with an input speed of 3000rpm.

HYS SERIES PRECISION PLANETARY GEAR MOTOR

■ Dimensions

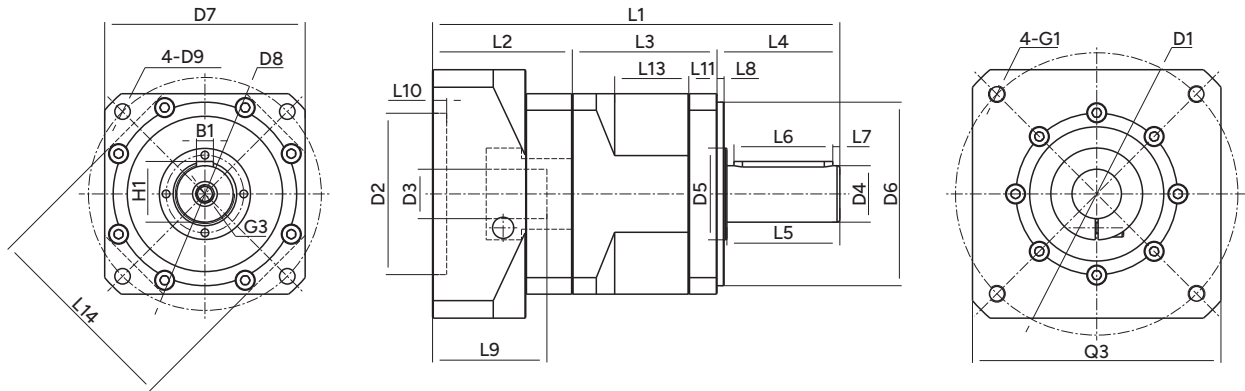

■ Unit: mm

Product type	115HYS		142HYS		190HYS	
Number of stage	1	2	1	2	1	2
L1 overall length	213	246.5	288.5	331.5	316.5	364.5
L3 body length	77.5	111	102.5	145.5	121.5	169
Output						
L4 output shaft length	64.5		87		90	
L5 output length to the shaft shoulder	58		80		82	
L6 key length	50		70		70	
L7 key length to the shaft end	4		5		6	
L8 protruding length	4		5		6	
L11 output flange thickness	14		20		20	
D4 output shaft diameter	Φ32h7		Φ40h7		Φ55h7	
D5 shaft shoulder diameter	Φ55		Φ65		Φ95	
D6 protruding diameter	Φ110h7		Φ130h7		Φ160h7	
D7 body diameter	□115		□142		□190	
D8 flange hole circle	Φ130		Φ165		Φ215	
D9 mounting bore	Φ8.5		Φ11		Φ13.5	
B1 key width	10		12		16	
H1 key height	35		43		59	
G3 center screw hole	M12x25		M12x25		M16x35	
L13 technical groove width	34	67.5	52.5	95.5	52	100
L14 technical groove	□115		□142		□190	
Input						
L2 input flange length	71		100		105	
L9 motor shaft length	58		79		82	
L10 protruding depth	10		10		8	
D1 mounting hole distribution circle	Φ145		Φ200		Φ215	
D2 protruding diameter	Φ110G7		Φ114.3G7		Φ180G7	
D3 input shaft diameter	≤Φ24G7		≤Φ35G7		≤Φ42G7	
G1 mounting threads hole x depth	M8x22		M12x25		M12x25	
Q3 input flange	□130		□175		□190	

※Input size made according to motor size.

Servo motor corresponding size table

■ Gearbox Input

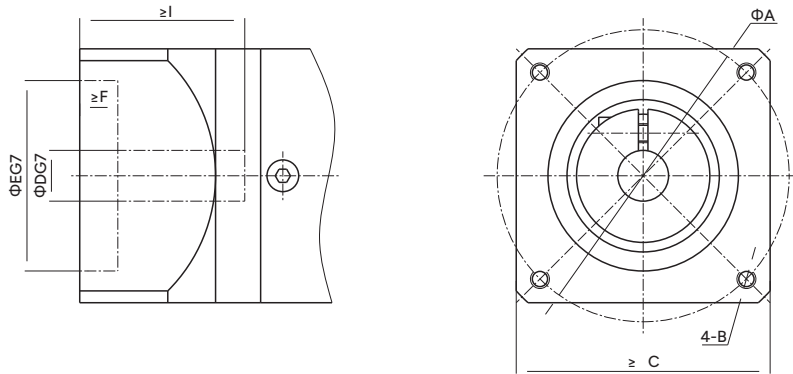

■ Input Flange And Servo Motor Matching Table

Motor Power (W)	Motor Size	Installation Distance	Threaded Hole	Frame	Bore diameter	Seam	Seam Depth	Shaft Extension
		A	B	C	D	E	F	I
50	T1	45	M3	38	8	30	3	25
	T2	46	M4	40	6	30	3	25
	T3	47	M4	40	8	30	3	25
	T4	48	M3	42	8	30	3	25
100	T1	45	M3	38	8	30	3	25
	T2	46	M4	40	8	30	3	25
	T3	46	M4	40	8	30	3	25
	T4	48	M3	42	8	30	3	25
200	T1	70	M4	60	11	50	3	30
	T2	70	M5	60	14	50	3	30
	T3	70	M5	60	14	50	3	30
400	T1	70	M4	60	14	50	3	30
	T2	70	M5	60	14	50	3	30
	T3	70	M5	60	14	50	3	30
750	T1	90	M5	80	19	70	3	35
	T2	90	M6	80	16	70	3	40
	T3	90	M6	80	19	70	3	40
	T4	100	M6	86	16	80	3	35
	T5	145	M8	130	19	110	6	58
	T6	100	M6	86	19	80	3	40
1000	T1	100	M6	90	19	80	3	55
	T2	115	M6	100	24	95	3	45
	T3	115	M8	100	24	95	5	45
	T4	145	M8	130	22	110	6	58
	T5	145	M8	130	22	110	6	70
	T6	115	M8	100	22	95	5	45
	T7	145	M8	130	24	110	3	55
1500	T1	115	M8	100	19	95	3	55
	T2	115	M6	100	24	95	3	45
	T3	115	M8	100	24	95	3	45
	T4	145	M8	130	22	110	6	58
	T5	145	M8	130	22	110	6	70
	T6	115	M8	100	22	95	5	45
	T7	145	M8	130	24	110	3	55

Servo motor corresponding size table

Input Flange And Servo Motor Matching Table

Motor Power (W)	Motor Size	Installation Distance	Threaded Hole	Frame	Bore diameter	Seam	Seam Depth	Shaft Extension
		A	B	C	D	E	F	I
2000	T1	115	M8	100	19	95	3	55
	T2	115	M6	100	24	95	3	45
	T3	115	M8	100	24	95	3	45
	T4	145	M8	130	22	110	6	58
	T5	200	M12	175	35	114.3	10	80
	T6	115	M8	100	22	95	5	45
2500	T1	115	M8	100	19	95	3	55
	T2	115	M6	100	24	95	3	45
3000	T1	130	M8	120	22	110	3	55
	T2	145	M8	130	28	110	6	65
	T4	145	M8	130	24	110	6	65
	T5	200	M12	175	35	114.3	10	80
	T7	200	M12	175	35	114.3	10	65
3500	T1	130	M8	120	22	110	3	55
	T2	145	M8	130	28	110	3	63
	T5	200	M12	175	35	114.3	10	80
4000	T1	145	M8	130	24	110	6	65
	T2	145	M8	130	28	110	6	65
	T5	200	M12	175	35	114.3	10	80
	T6	200	M12	175	42	114.3	10	113
4500	T1	145	M8	130	24	110	6	65
	T5	200	M12	175	35	114.3	10	80
	T6	200	M12	175	42	114.3	10	113
	T7	200	M12	175	35	114.3	10	65
5000	T1	145	M8	130	24	110	6	65
	T2	145	M8	130	28	110	6	65
	T5	200	M12	175	35	114.3	10	80
	T7	200	M12	175	35	114.3	10	65

1. If an oil-seal is not present and the size is different, attachment of the oil-seal may correspond to special order, in some cases.
2. If the motor shaft is of D-cut and taper type, it corresponds to a special order.
3. Out-of-standard may correspond to a special order in some cases, For details, contact us.

Assembly Procedure

If a customer personally assembles the servo motor and reducer please use the following tip. The reducer flange to which the servo motor is attached has different dimensions based on the motor specified. Therefore, assembly may be impossible for some motor. Make sure the correct motor is specified before ordering the reducer.

1. Assembling A Motor Without Key

① Take off the rubber cap, turn the input shaft, and match the head of the bolt to the hole of the set screw. Make sure that the set bolt is loosened.

② Gradually put the motor shaft into the input shaft (Ensure that it is smoothly put in without jam.)

Be careful not to insert with the motor tilted.

③ Attach the motor to the reducer and fasten the bolt with designated fastening torque. See Table 1.

④ Fasten the set bolt of the input shaft with designated fastening torque wrench, etc. See Table 2.

⑤ Put on the rubber cap. It is the end of assembling.

● Table1

Motor Fix Bolt	Fastening Torque	
	(N·m)	(kgf·cm)
M3	1.0	10
M4	3.0	30
M5	5.8	60
M6	9.8	100
M8	19.6	200
M10	39.2	400
M12	68.6	700
M16	168	1650

● Table2

Fix Bolt	Fastening Torque	
	(N·m)	(kgf·cm)
M3	1.5	15
M4	3.5	35
M5	7.1	71
M6	12	120
M8	30	300
M10	60	612

You can assemble the motor with keyway like above when take off the key. There is no risk of slip.

● HYE/F/WE/WF/S Series Schematic Diagram

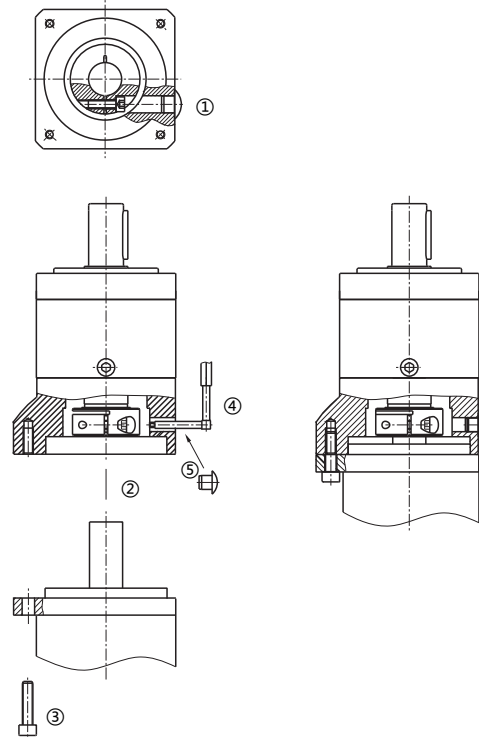

Reducer Assembly

When assemble a reducer onto equipment, make sure that the combining surface is flat and no burrs. Use specified torque to fix bolt, See Table 4.

● Table4

Reducer Fix Bolt	Fastening Torque	
	(N·m)	(kgf·cm)
M5	5.8	60
M6	9.8	100
M8	19.6	200
M10	39.2	400
M12	68.6	700
M16	16.8	1650

Connection To The Output Shaft

Cautions:

- 1、 When assemble a coupling, pulley, etc. onto the output shaft,make sure that there's no excessive axial load.
- 2、 In case of strongly hitting the shaft with a hammer, the bearing or the inside of the reducer may be damaged, therefore it shall be prohibited.
- 3、 If the shaft or key of a coupling assembled is loosed, it may cause damage, so be careful when assembling.
- 4、 For assembling of a coupling, fix the key with a set bolt.
- 5、 Please adjust shaft centre carefully in connecting.

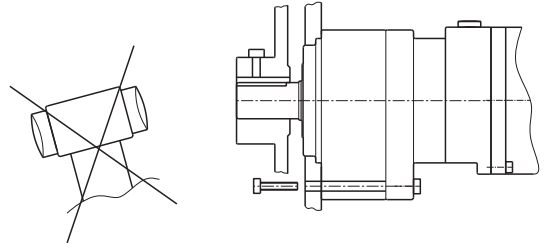



HIGH PRECISION PLANETARY GEAR BOX CATALOGUE

Deputy Procurement Manager:Ming
Tel: +(86)18067150331
E-mail: info@hy-motor.com
Web: www.hy-motor.com

NINGBO HENGYAO TRADING CO.,LTD.
Add: No. 7, Qianzhai Road, Cixi City, Ningbo City, Zhejiang Province.