



DC BRUSHLESS GEAR MOTOR



DC BRUSHLESS GEAR MOTOR

Easy and simple to achieve speed control.



Description of brushless DC motor characteristic curve

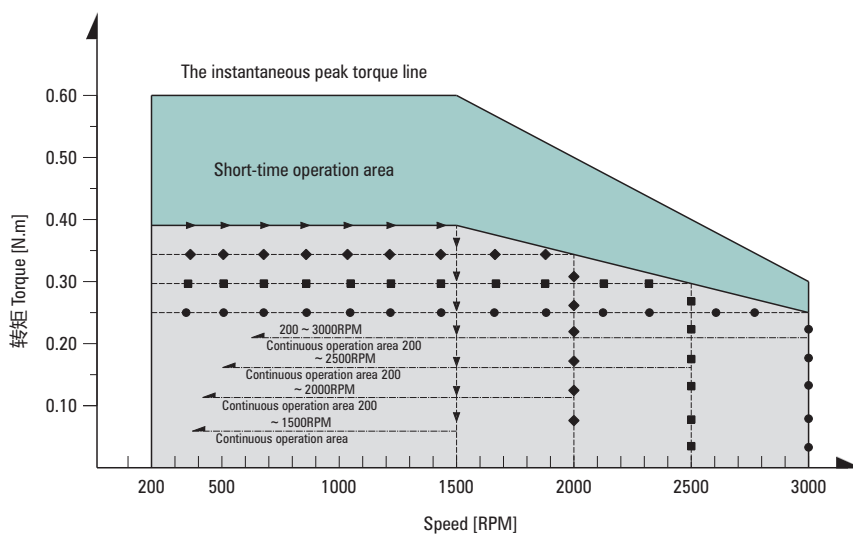

- The instantaneous maximum torque line: The maximum torque during motor start-up and instantaneous impact load; exceeding this torque value will cause the driver's overcurrent protection to trip, resulting in a shutdown.
- Short-time operation area: When the motor at different speed, it can operate in a short time during this torque range. but after a long time it can cause heating of the motor, resulting motor break or drive overheat protection start, cause stopping working.
- Rated operation torque line: At different speeds, the motor can run for a long time.
- In continuous operation area: At different speed, the motor can operate.

PRODUCT FEATURES

The characteristics of brushless motor

About brushless motors, there is no need to use mechanical contacts such as brushes and commutators, which are commonly considered drawbacks of DC motors. DC motors use brushes and commutators to rotate, thus requiring regular maintenance. In contrast, brushless motors utilize signals detected by Hall ICs and rotate by the ON/OFF of transistors in the drive circuit, eliminating the need for maintenance.

Stable speed control

Brushless motors continuously compare the set speed with the speed feedback signal from the motor to adjust the voltage applied to the motor. Therefore, even if the load condition changes, they can instantly adjust from low speed to the set speed and operate at this stable speed. Three-phase induction motors controlled by a frequency converter do not perform feedback control, so when the load increases, the speed will drop significantly. For applications that require high speed stability it is recommended to use brushless motors.

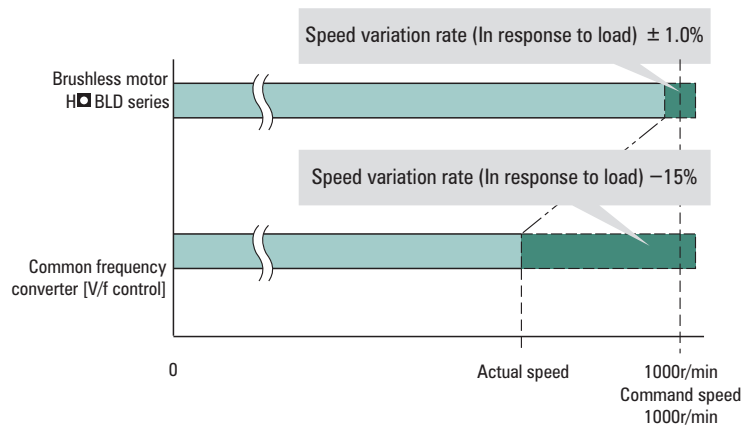

Wide speed control range

Brushless motors have a wider speed control range compared to AC adjustable-speed motors and frequency converters. Since they do not have torque limitations at low speeds as seen with AC adjustable-speed motors, brushless motors are suitable for applications that require a certain amount of torque from low speeds to high speeds.

Product style	Speed control range	Rate ratio
Brushless motor	80~3000	50
Frequency converter control Three phase induction motor	200~2400	12
AC adjustable-speed motors	50Hz: 90~1400	15
	60Hz: 90~1600	17

Saving energy

The rotor of the brushless motor utilizes permanent magnets, which can reduce secondary losses of the rotor. Therefore, compared to three-phase induction motors controlled by frequency conversion, brushless motors consume about 23% less power, contributing to energy savings in devices.

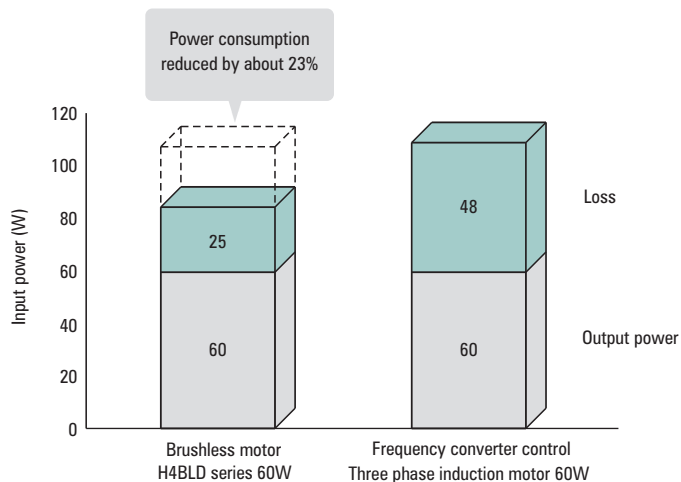

Low speed and high torque performance

HY brushless motor have a steady big torque when running at low speed.

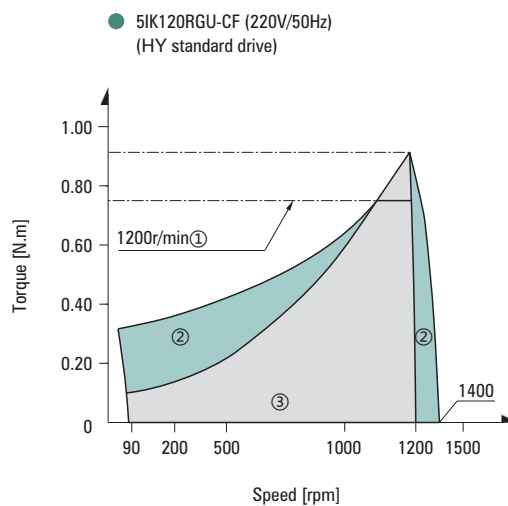
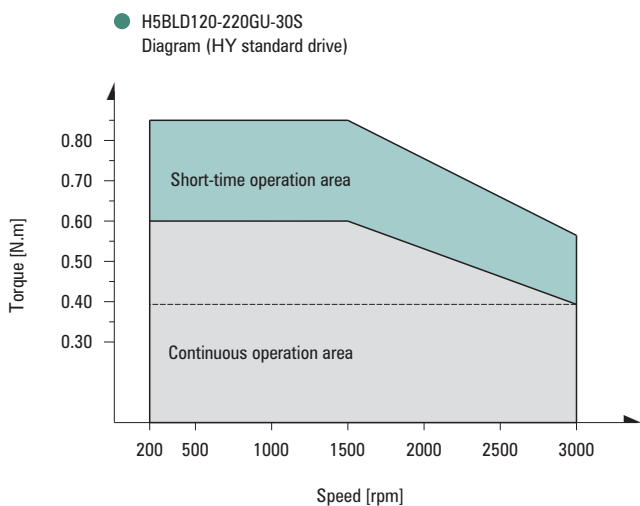

①1200r/min torque line ②Short-time operating area ③Continuous operation area

● Working performance table of brushless motor and ac speed adjustable motor

No.	H5BLD120-220GU-25S					5IK120RGU-CF				
	Torque N.m	Speed rpm	Current A	Efficiency %	Temperature rise K	Torque N.m	Speed rpm	Current A	Efficiency %	Temperature rise K
1	0.595	200	0.485	26.5	≤50K	0.010	200	0.850	3.00	≤80K
2	0.595	500	0.671	47.5	≤50K	0.150	500	1.070	8.00	≤80K
3	0.595	1000	0.966	62.0	≤40K	0.500	1000	1.186	32.5	≤80K
4	0.595	1500	1.200	69.0	≤40K	0.915	1400	0.981	60.0	≤55K

Ambient temperature -10°C~+40°C

Thin, high power

Brushless HY motors have a slim body and provide high power due to permanent magnets being used in the rotor. For example, the overall length is 75mm shorter and the output power is 1.3 times higher than that of three-phase induction motors with a frame size of 90mm. Using brushless DC motors can contribute to downsizing and space saving.

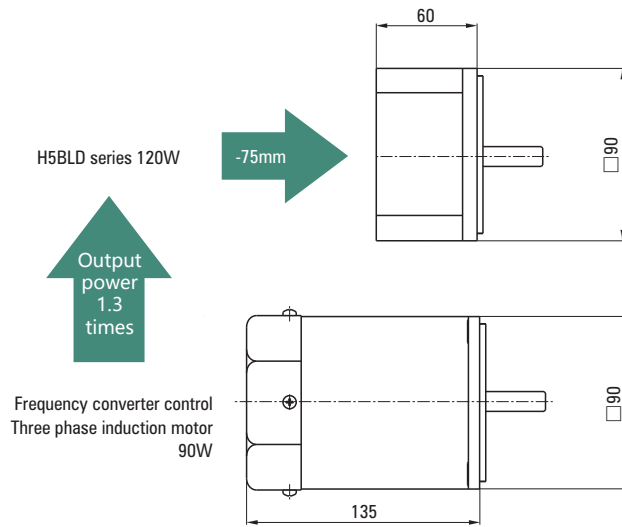

Protection function, help to protect the safety of the equipment system



Due to the load of the overcurrent, undervoltage, open phase protection, Our motor and driver can ensure the safety of equipment system.

Motor spec — Speed

Motor speed	Output shaft speed	Reduction ratio												
		3	3.6	5	6	7.5	9	10	12.5	15	18	20	25	
200~1500RPM		67~500	56~417	40~300	33~250	27~200	22~167	20~150	16~120	13~100	11~83	10~75	8~60	
2000RPM		667	556	400	334	267	222	200	160	133	111	100	80	
2500RPM		833	694	500	417	333	278	250	200	167	139	125	100	
3000RPM		1000	833	600	500	400	333	300	240	200	167	150	120	

Motor speed	Output shaft speed	Reduction ratio										
		30	36	50	60	75	90	100	120	150	180	200
200~1500RPM		7~50	6~42	4~30	3~25	3~20	2~17	2~15	2~12.5	1.5~10	1~8	1~7.5
2000RPM		67	56	40	33	27	22	20	17	13	11	10
2500RPM		83	69	50	42	33	28	25	21	17	14	13
3000RPM		100	83	60	50	40	33	30	25	20	17	15

Motor spec — Product type

Motor	quare size	Output power	Model	Driver	Voltage supply
	60X60	15、25	Standard type IP40 or IP54		DC24~48 Single phase 100~120V Single phase 220~240V
	70X70	30、40			
	80X80	40、60			
	90X90 (GN)	40、60			
	90X90 (GU)	60、90、120			
	104X104	200、400			
	120X120	750、1000			

Item		Motor	Driver
Insulation Resistance (Do not test when the motor is connected to the drive.)		In a constant temperature and humidity environment, after continuous operation, the measured value between the motor winding and the casing using a DC 500V ohmmeter should be above 50MΩ.	After continuous operation in a constant temperature and humidity environment, the resistance between the power terminals and the protective ground terminals, as well as between the power terminals and the input/output signal terminals, should be measured to be above 50MΩ using a DC 500V ohmmeter.
Dielectric Withstand Voltage (Testing is not allowed with the motor connected to the drive.)		After continuous operation in a constant temperature and humidity environment, applying a 50Hz AC voltage of 1.5kV between the winding and the casing for 1 minute should result in no abnormalities, with a leakage current of less than 10mA.	After continuous operation in a constant temperature and humidity environment, no abnormalities should occur when a 50Hz AC voltage of 1.5kV is applied for 1 minute between the power terminals and the protective ground terminals, as well as between the power terminals and the input/output signal terminals.
Temperature rise		After continuous operation in a constant temperature and humidity environment, the temperature rise of the winding measured by the thermocouple method should be below 55°C, and the temperature rise of the outer shell surface should be below 40°C.	After continuous operation in a constant temperature and humidity environment, the temperature rise of the aluminum heat sink measured by the thermocouple method should be below 50°C.
Operating Environment	Ambient Temperature	-10°C ~ +40°C (Icing-Free)	
	Humidity	Below 85% (Frost-Free)	
	Altitude	Below 1000m	
	Medium Environment	Free from corrosive gases and dust; not to be used in special environments containing radioactive materials, magnetic fields, and vacuum	
Vibration		Continuous vibration or excessive shock should not be applied	
Storage Environment ②	Ambient Temperature	-10°C ~ +40°C (Icing-Free)	
	Humidity	85% or less (Frost-Free)	
	Altitude	Below 1000m	
Thermal Class		Class B	/
Protection level		IP40 & IP54	IP20

- ① To maintain the surface temperature of the electric motor casing below 90°C, the motor should be mounted on a heat sink (material: aluminum) of the following dimensions; for a 25W motor: 115mm x 115mm x 5mm thickness, for a 60W motor: 135mm x 135mm x 5mm thickness, for a 120W motor: 165mm x 165mm x 5mm thickness, and for a 200W motor: 200mm x 200mm x 5mm thickness. (Unit: mm)
- ② The storage condition applies to a short period such as a period during transportation.

PRODUCT CODE

Motor

H 5 BLD 90 - 220 GN(L) - 30S - M
 ① ② ③ ④ ⑤ ⑥ ⑦ ⑧

①	Company	HY MOTOR					
②	Type	Model & Dimension					
	Frame code	2	3	4	5	6	7
	Mounting flange mm	<input type="checkbox"/> 60	<input type="checkbox"/> 70	<input type="checkbox"/> 80	<input type="checkbox"/> 90	<input type="checkbox"/> 104	<input type="checkbox"/> 120
	Housing dimension	60*60	70*70	80*80	90*90	104*104	120*120
③	Motor type	BLD: DC Brushless gear motor					
④	(W) Output power (W)	(e.g) 90: 90W					
⑤	Voltage	(e.g) 24: 24VDC (Optional voltage 24V~48VDC, single phase 100V~120VAC, single phase 220V~240VAC, 50/60Hz)					
⑥	Relative to square type gear box: Motor shaft type	GN: GN type gear shaft GU: GU type gear shaft					
	L type gearbox: Shaft shape	GNL: Type L GN series gear shaft (Mainly for 2&4 series) GUL: Type L GU series gear shaft (Mainly for 5&6 series)					
	Shaft type for only motor: A: Round shaft type	A1: Keyway type					
⑦	Motor speed						
⑧	Motor parts	M: Electromagnetic brake BM: Closed loop feedback mode, generally refers to the motor to increase the encoder (Including the simple holzer encoder)					

Square shape gearbox

5 GN 50 K
 ① ② ③ ④

①	Gearhead frame size	2: 60mm 3: 70mm 4: 80mm 5: 90mm 6: 104mm 7: 120mm
②	Gear type	GN: GN type gear GU:GU type gear
③	Gear ratio	(e.g)50: Reduction ratio
④	Bearing type	K: Ball bearing (On the GU type square box marked as KB)

L type gearbox

5 GU 50 LC
 ① ② ③ ④

①	Gearhead frame size	2: 60mm 3: 70mm 4: 80mm 5: 90mm 6: 104mm 7: 120mm
②	Gear type	GN: Type GN gear shaft (For L series 2&4) GU: Type GU gear shaft (For L series 5&6)
③	Gear ratio	(e.g)50: Reduction ratio
④	Bearing type	LC: L type hollow shaft output reducer RC:Hollow shaft output of spiral bevel gear RT:Solid shaft output of spiral bevel gear

60 SERIES OF BRUSHLESS DC MOTOR

Basic characteristics of motor

● 25W (DC power supply is suitable for 24VDC/36VDC/48VDC)

Rated power (Continuous)	W	25 (15W/25W)			
Rated speed	r/min	3000			
Rated torque	N.m	0.08			
Instantaneous maximum torque	N.m	0.12			
Rotor moment of inertia	J: $\times 10^{-4} \text{kg.m}^2$	0.042			
Speed control range	RPM	200~3000			
Speed control range	On load	Below $\pm 1\%$: Condition 0~rated torque, rated speed, rated voltage, room temperature			
	On voltage	Below $\pm 1\%$: Condition rated voltage $\pm 10\%$, rated speed, rated load, room temperature			
	On temperature	Below $\pm 1\%$: Conditions of ambient temperature $-10^\circ\text{C} \sim +40^\circ\text{C}$ rated voltage, rated load and rated speed			
Power input	Rated voltage	V	Single phase 110V	Single phase 220V	24VDC (Optional 36VDC/48VDC)
	Voltage tolerance range		$\pm 10\%$		
	Frequency	Hz	50/60	/	
	Frequency tolerance range		$\pm 5\%$		
	Rated input current	A	1.0	0.6	1.7
	Instantaneous maximum input current	A	2.0	1.2	2.6

Round shaft type only motor

● H2BLD25-A-30S Voltage24/36/48/110/220

● H2BLD25-220A-30S
Diagram (HY standard drive)

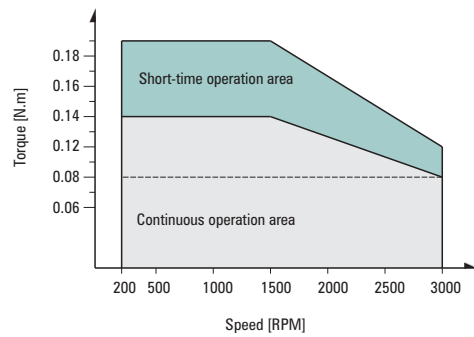
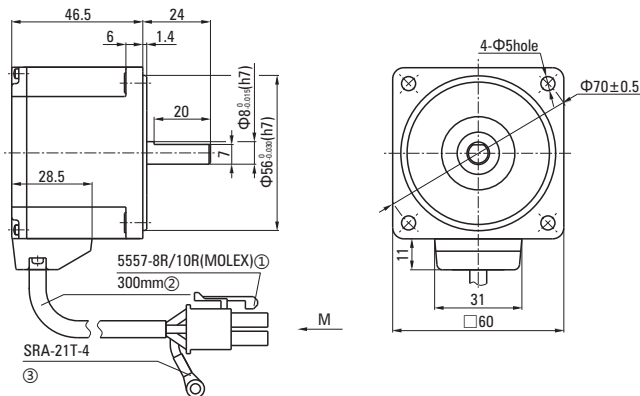

①Connector: 5557-8R/10R (MOLEX) ②The length of lead line 300mm ③Round terminal: SRA-21T-4 (No ground for low voltage)

● Low voltage wire plughole corresponding signal explanation

● High voltage wire plughole corresponding signal explanation

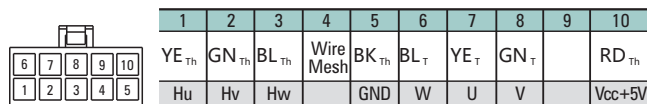
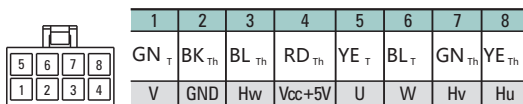

25W

● Parallel shaft gearbox

H2BLD25-□GN-30S/2GN□K □—Voltage 24/36/48/110/220
□—Reduction ratio 30

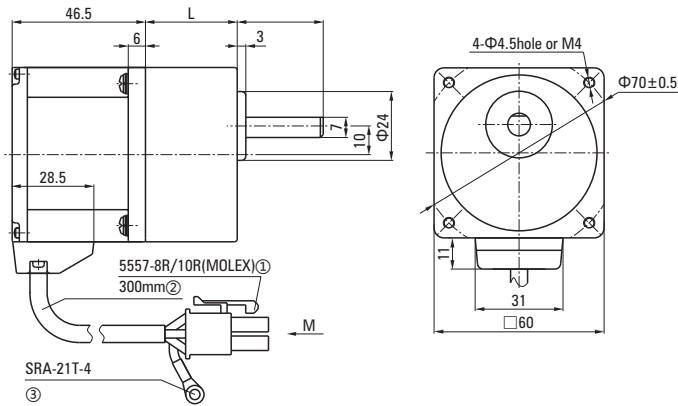

①Connector: 5557-8R/10R (MOLEX) ②The length of lead line 300mm ③Round terminal: SRA-21T-4 (No ground for low voltage)

● Decimal gearbox

2GN□XK
□Velocity ratio value, generally 10

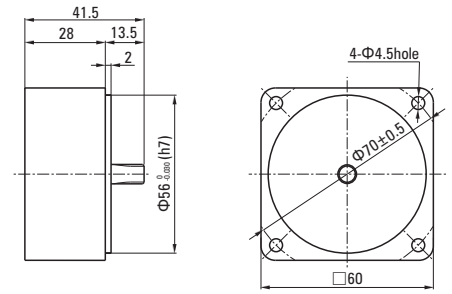

Gearhead model	Gear ratio	Dimension
2GN□K	3~18	32&41
	20~200	41

● □ means gearbox ratio

● H2BLD15-□GN-30S/2GN□K gearmotor allowable torque (Unit: N.m)

Model	Reduction ratio Motor speed	Reduction ratio																							
		3	3.6	5	6	7.5	9	10	12.5	15	18	20	25	30	36	50	60	75	90	100	120	150	180	200	
H2BLD15-□GN	200~1500RPM	0.18	0.22	0.30	0.36	0.45	0.54	0.60	0.75	0.91	1.08	1.09	1.36	1.63	1.96	2.72	3.00	3.00	3.00	3.00	3.00	3.00	3.00	3.00	3.00
	2000RPM	0.15	0.18	0.26	0.31	0.38	0.45	0.51	0.64	0.77	0.92	0.92	1.15	1.38	2.30	2.50	3.00	3.00	3.00	3.00	3.00	3.00	3.00	3.00	3.00
	2500RPM	0.14	0.17	0.23	0.28	0.35	0.42	0.46	0.58	0.70	0.84	0.84	1.05	1.25	1.51	2.09	2.27	2.83	3.00	3.00	3.00	3.00	3.00	3.00	3.00
	3000RPM	0.12	0.14	0.19	0.23	0.29	0.35	0.39	0.48	0.58	0.70	0.70	0.87	1.05	1.25	1.74	1.88	2.35	2.82	3.00	3.00	3.00	3.00	3.00	3.00

● H2BLD25-□GN-30S/2GN□K gearmotor allowable torque (Unit: N.m)

Model	Reduction ratio Motor speed	Reduction ratio																							
		3	3.6	5	6	7.5	9	10	12.5	15	18	20	25	30	36	50	60	75	90	100	120	150	180	200	
H2BLD25-□GN	200~1500RPM	0.30	0.36	0.50	0.60	0.75	0.91	1.00	1.26	1.51	1.81	1.81	2.27	2.72	3.00	3.00	3.00	3.00	3.00	3.00	3.00	3.00	3.00	3.00	3.00
	2000RPM	0.26	0.31	0.43	0.51	0.64	0.77	0.85	1.06	1.28	1.53	1.53	1.92	2.30	2.76	3.00	3.00	3.00	3.00	3.00	3.00	3.00	3.00	3.00	3.00
	2500RPM	0.23	0.28	0.39	0.46	0.58	0.69	0.77	0.97	1.16	1.39	1.39	1.74	2.09	2.51	3.00	3.00	3.00	3.00	3.00	3.00	3.00	3.00	3.00	3.00
	3000RPM	0.19	0.23	0.32	0.39	0.48	0.58	0.64	0.81	0.97	1.16	1.16	1.45	1.74	2.09	2.90	3.00	3.00	3.00	3.00	3.00	3.00	3.00	3.00	3.00

Note : The (Grey background area) in the table indicates that the rotation direction is same as the motor
(The torque under different speed and speed ratio is obtained under the HY standard)

● L type gearbox

H2BLD25-□GNL-30S/2GN□LC □—Voltage 24/36/48/110/220
□—Reduction ratio

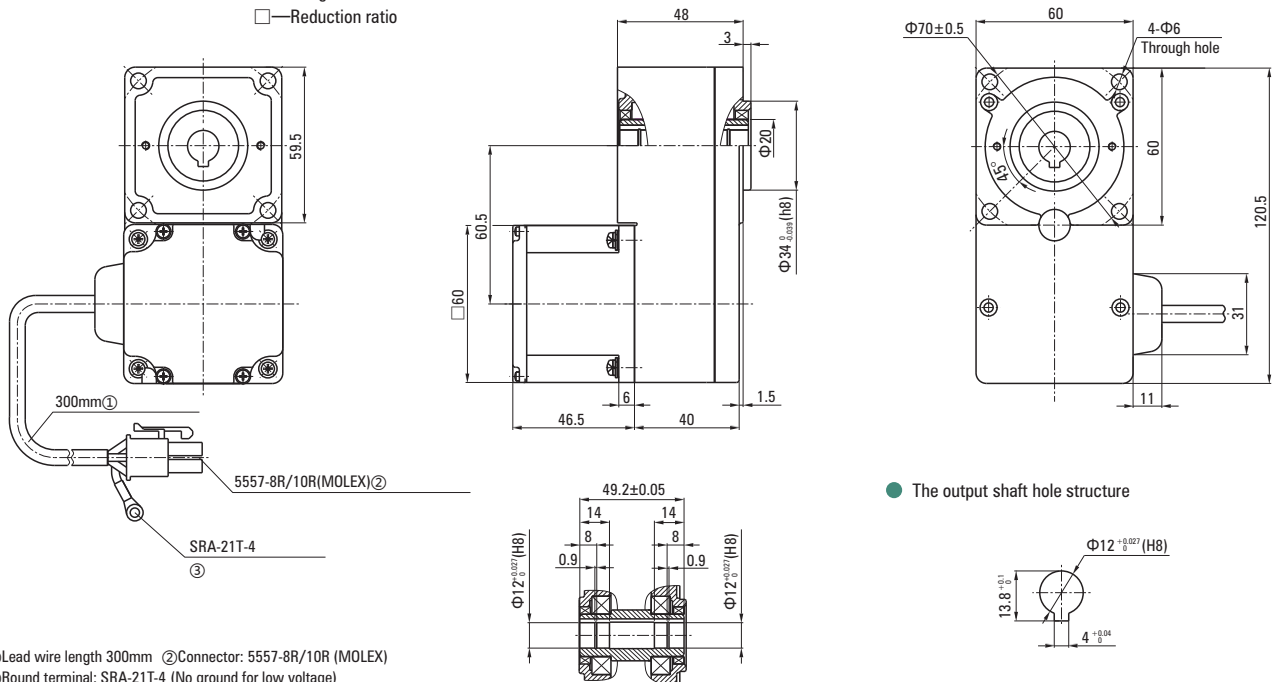

①Lead wire length 300mm ②Connector: 5557-8R/10R (MOLEX)
③Round terminal: SRA-21T-4 (No ground for low voltage)

● The output shaft hole structure

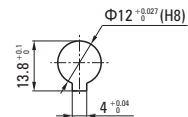

● H2BLD15-□ GNL-30S/2GN□ LC gearmotor allowable torque (Unit: N.m)

Motor Speed \ Reduction Ratio	5	10	15	20	30	50	100	200
200~1500RPM	0.27	0.54	0.82	1.09	1.63	2.72	5.44	10.9
2000RPM	0.23	0.46	0.69	0.92	1.38	2.30	4.60	9.20
2500RPM	0.21	0.42	0.63	0.84	1.25	2.09	4.18	8.37
3000RPM	0.17	0.35	0.52	0.70	1.05	1.74	3.49	6.97

Note : All gearbox output turn direction in form are opposite motor turn direction.
(The torque under different speed and speed ratio is obtained under the HY standard.)

● H2BLD25-□ GNL-30S/2GN□ LC gearmotor allowable torque (Unit: N.m)

Motor Speed \ Reduction Ratio	5	10	15	20	30	50	100	200
200~1500RPM	0.50	1.00	1.51	2.01	2.72	4.53	9.06	16.40
2000RPM	0.43	0.85	1.28	1.70	2.30	3.83	7.67	13.90
2500RPM	0.39	0.77	1.16	1.55	2.09	3.49	6.97	12.60
3000RPM	0.29	0.58	0.87	1.16	1.74	2.90	5.81	11.62

Note : All gearbox output turn direction in form are opposite motor turn direction.
(The torque under different speed and speed ratio is obtained under the HY standard.)

70 SERIES OF BRUSHLESS DC MOTOR

Basic characteristics of motor

- 40W (DC power supply is suitable for 24VDC/36VDC/48VDC)

Rated power (Continuous)	W	40 (40W)			
Rated speed	r/min	3000			
Rated torque	N.m	0.127			
Instantaneous maximum torque	N.m	0.191			
Rotor moment of inertia	J: $\times 10^{-4} \text{kg.m}^2$	0.082			
Speed control range	RPM	200~3000			
Speed control range	On load	Below $\pm 1\%$: Condition 0~rated torque, rated speed, rated voltage, room temperature			
	On voltage	Below $\pm 1\%$: Condition rated voltage $\pm 10\%$, rated speed, rated load, room temperature			
	On temperature	Below $\pm 1\%$: Conditions of ambient temperature $-10^\circ\text{C} \sim +40^\circ\text{C}$ rated voltage, rated load and rated speed			
Power input	Rated voltage	V	24VDC (Optional 36VDC/48VDC)		
	Voltage tolerance range		$\pm 10\%$		
	Frequency	Hz	50/60	/	
	Frequency tolerance range		$\pm 5\%$		
	Rated input current	A	1.7	1.0	3.7
	Instantaneous maximum input current	A	3.3	1.9	5.6

Round shaft type only motor

- H3BLD40-A-30S — Voltage 24/36/48

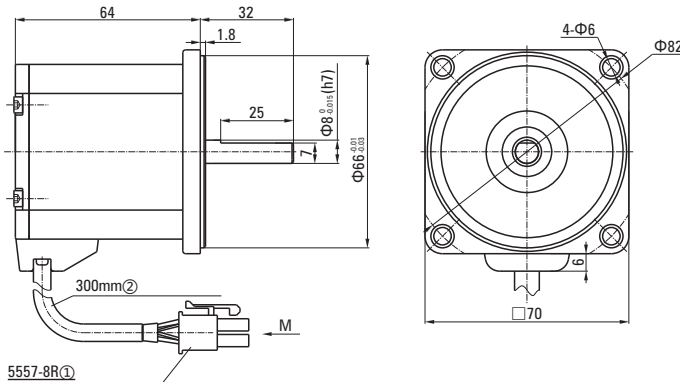

①Connector: 5557-8R ②The length of lead line 300mm

- H3BLD40-220A-30S
Diagram (HY standard drive)

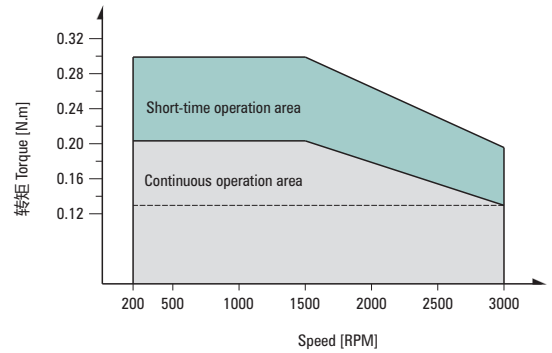

- Low voltage wire plughole corresponding signal explanation

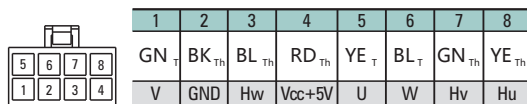

- High voltage wire plughole corresponding signal explanation

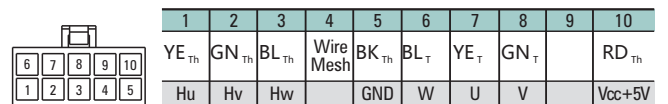

- L type gearbox
H3BLD40-GNL-30S/3GNLC Voltage 24/36/48
 Reduction ratio

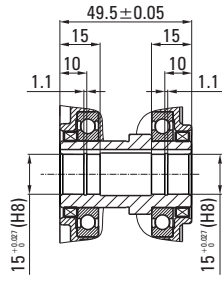
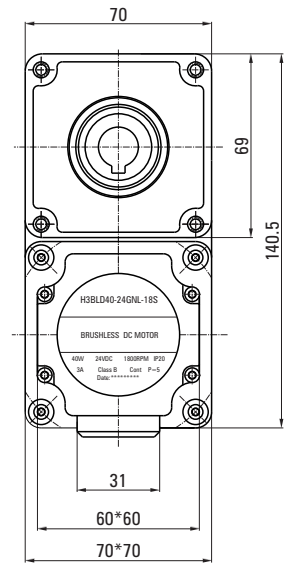
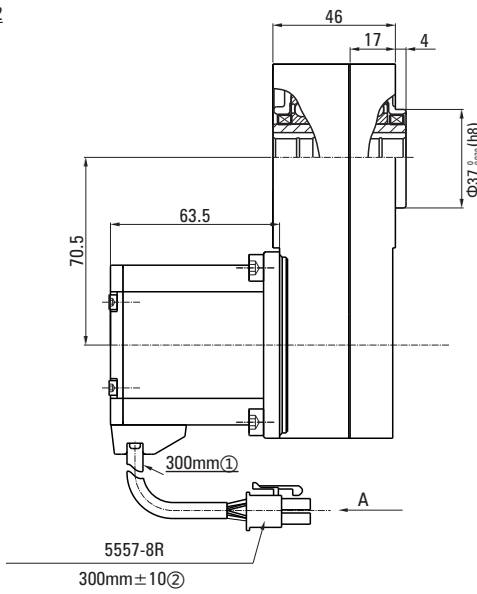
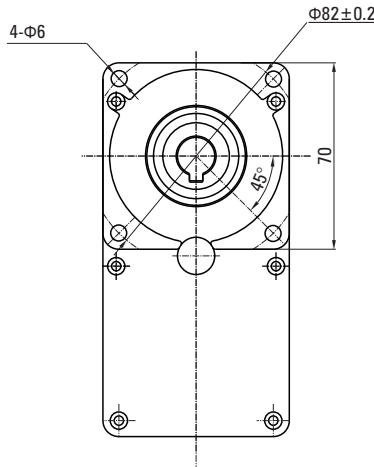

- The output shaft hole structure

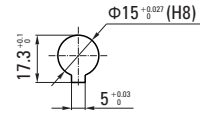

- ① Lead wire length 300mm
- ② Connector: 5557-8R Length of sheath outgoing line

- H3BLD40-24GNL-30S/3GNLC gearmotor allowable torque (Unit: N.m)

Reduction ratio \ Motor speed	5	10	15	20	30	50	60	90	100
1800RPM	0.77	1.55	2.32	3.10	4.65	7.75	9.30	13.94	15.49
3000RPM	0.46	0.93	1.39	1.86	2.79	4.65	5.58	8.37	9.30

Note : All gearbox output turn direction in form are opposite motor turn direction.
(The torque under different speed and speed ratio is obtained under the HY standard.)

80 SERIES OF BRUSHLESS DC MOTOR

Basic characteristics of motor

● 60W (DC power supply is suitable for 24VDC/36VDC/48VDC)

Rated power (Continuous)		W	60 (40W/60W)		
Rated speed		r/min	3000		
Rated torque		N.m	0.191		
Instantaneous maximum torque		N.m	0.287		
Rotor moment of inertia		J:×10 ⁻⁴ kg.m ²	0.082		
Speed control range		RPM	200~3000		
Speed control range	On load	Below ±1%: Condition 0~rated torque, rated speed, rated voltage, room temperature			
	On voltage	Below ±1%: Condition rated voltage ±10%, rated speed, rated load, room temperature			
	On temperature	Below ±1%: Conditions of ambient temperature -10°C~+40°C rated voltage, rated load and rated speed			
Power input	Rated voltage	V	Single phase 110V	Single phase 220V	24VDC (Optional 36VDC/48VDC)
	Voltage tolerance range	±10%			
	Frequency	Hz	50/60	/	
	Frequency tolerance range	±5%			
	Rated input current	A	1.7	1.0	3.7
	Instantaneous maximum input current	A	3.3	1.9	5.6

Round shaft type only motor

● H4BLD60-□A-30S □— Voltage 24/36/48/110/220

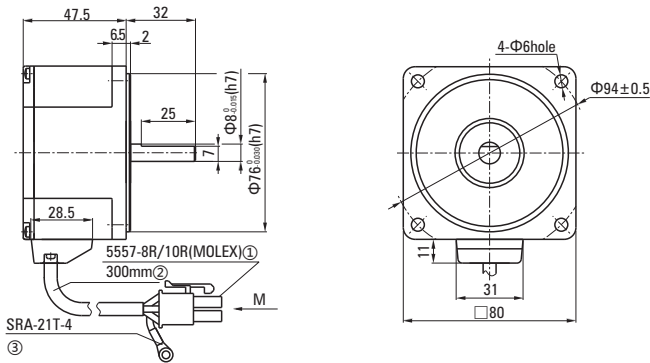

①Connector: 5557-8R/10R (MOLEX) ②The length of lead line 300mm ③Round terminal: SRA-21T-4 (No ground for low voltage)

● H4BLD60-220A-30S Diagram (HY standard drive)

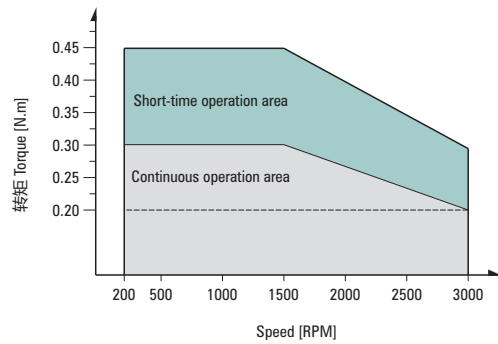

● Low voltage wire plughole corresponding signal explanation

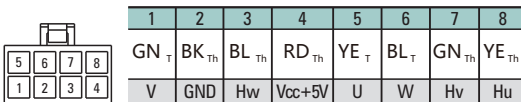

● High voltage wire plughole corresponding signal explanation

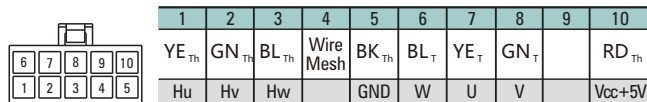

60W

● Parallel shaft gearbox

H4BLD60- GN-30S/4GN K — Voltage
24/36/48/110/220 — Reduction ratio

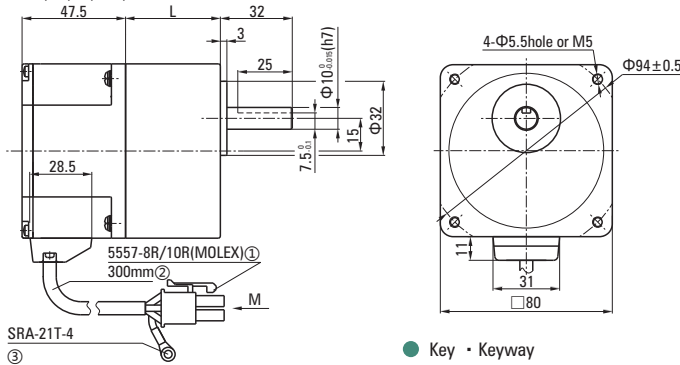

● Key · Keyway

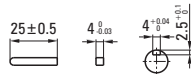

①Connector: 5557-8R/10R (MOLEX) ②The length of lead line 300mm ③Round terminal: SRA-21T-4 (No ground for low voltage)

● H4BLD40- GN-30S/4GN K gearmotor allowable torque (Unit: N.m)

Model	Reduction ratio Motor speed	Reduction ratio																							
		3	3.6	5	6	7.5	9	10	12.5	15	18	20	25	30	36	50	60	75	90	100	120	150	180	200	
H4BLD40- <input type="checkbox"/> GN	200~1500RPM	0.48	0.58	0.80	0.97	1.21	1.45	1.61	2.01	2.41	2.90	2.90	3.63	4.35	5.22	7.25	7.87	8.00	8.00	8.00	8.00	8.00	8.00	8.00	8.00
	2000RPM	0.41	0.49	0.68	0.82	1.02	1.23	1.36	1.70	2.04	2.45	2.45	3.07	3.68	4.42	6.13	6.66	8.00	8.00	8.00	8.00	8.00	8.00	8.00	8.00
	2500RPM	0.37	0.45	0.62	0.74	0.93	1.11	1.24	1.55	1.86	2.23	2.23	2.79	3.35	4.02	5.58	6.05	7.56	8.00	8.00	8.00	8.00	8.00	8.00	8.00
	3000RPM	0.31	0.37	0.52	0.62	0.77	0.93	1.03	1.29	1.55	1.86	1.86	2.32	2.79	3.35	4.65	5.01	6.26	7.52	8.00	8.00	8.00	8.00	8.00	8.00

● H4BLD60- GN-30S/4GN K gearmotor allowable torque (Unit: N.m)

Model	Reduction ratio Motor speed	Reduction ratio																							
		3	3.6	5	6	7.5	9	10	12.5	15	18	20	25	30	36	50	60	75	90	100	120	150	180	200	
H4BLD60- <input type="checkbox"/> GN	200~1500RPM	0.72	0.87	1.21	1.45	1.81	2.17	2.41	3.02	3.62	4.34	4.35	5.44	6.53	7.83	8.00	8.00	8.00	8.00	8.00	8.00	8.00	8.00	8.00	8.00
	2000RPM	0.61	0.74	1.02	1.23	1.53	1.84	2.04	2.55	3.06	3.68	3.68	4.60	5.52	6.63	8.00	8.00	8.00	8.00	8.00	8.00	8.00	8.00	8.00	8.00
	2500RPM	0.56	0.67	0.93	1.11	1.39	1.67	1.86	2.32	2.78	3.34	3.35	4.18	5.02	6.02	8.00	8.00	8.00	8.00	8.00	8.00	8.00	8.00	8.00	8.00
	3000RPM	0.46	0.56	0.77	0.93	1.16	1.39	1.55	1.93	2.32	2.78	2.79	3.49	4.18	5.02	6.97	7.52	8.00	8.00	8.00	8.00	8.00	8.00	8.00	8.00

Note : The (Grey background area) in the table indicates that the rotation direction is same as the motor
(The torque under different speed and speed ratio is obtained under the HY standard.)

● L type speed reducer

H4BLD60- — Voltage 24/36/48/110/220
GNL-30S/4GN LC — Reduction ratio

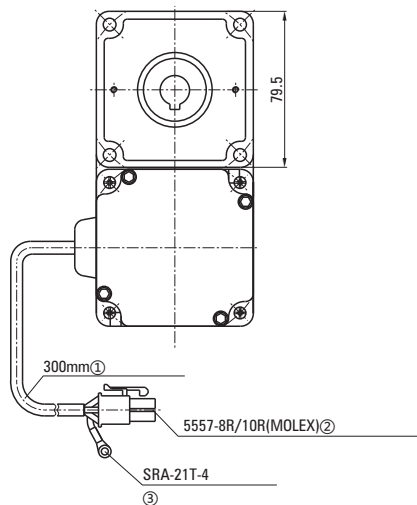

①Lead wire length 300mm ②Connector: 5557-8R/10R (MOLEX)
③Round terminal: SRA-21T-4 (No ground for low voltage)

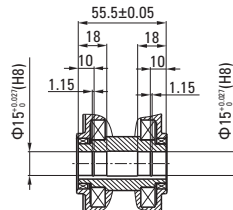
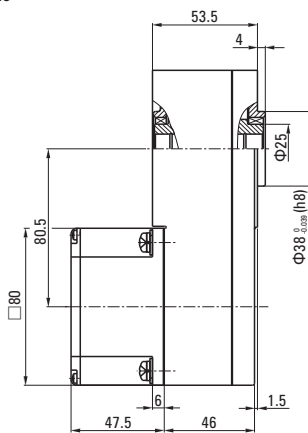

● The output shaft hole structure

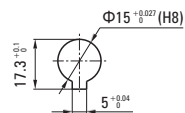

● Decimal gearbox

4GN XK
 Velocity ratio value, generally 10

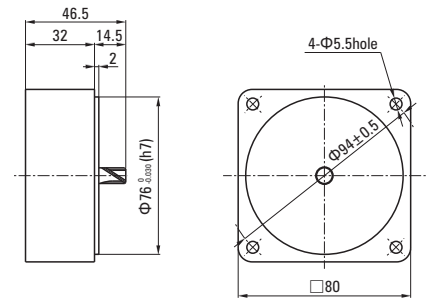

Gearhead model	Gear ratio	Dimension
4GN <input type="checkbox"/> K	3~18	32&43.5
	20~200	43.5

● means gearbox ratio

● H4BLD40-□GNL-30S/4GN□LC gearmotor allowable torque (Unit: N.m)

Motor speed \ Reduction ratio	5	10	15	20	30	50	100	200
200~1500RPM	0.73	1.45	2.18	2.90	4.35	7.25	14.50	29.00
2000RPM	0.61	1.23	1.84	2.45	3.68	6.13	12.30	24.50
2500RPM	0.56	1.12	1.67	2.23	3.35	5.58	11.20	22.30
3000RPM	0.46	0.93	1.39	1.86	2.79	4.65	9.30	18.59

● H4BLD60-□GNL-30S/4GN□LC gearmotor allowable torque (Unit: N.m)

Motor speed \ Reduction ratio	5	10	15	20	30	50	100	200
200~1500RPM	1.21	2.41	3.62	4.83	6.53	10.9	21.80	39.30
2000RPM	1.02	2.04	3.06	4.08	5.52	9.20	18.40	33.30
2500RPM	0.93	1.86	2.78	3.71	5.02	8.37	16.70	30.30
3000RPM	0.70	1.39	2.09	2.79	4.18	6.97	13.94	27.89

Note : All gearbox output turn direction in form are opposite motor turn direction.
(The torque under different speed and speed ratio is obtained under the HY standard.)

● Arc cone right angle speed reducer motor

H4BLD60-□GN-30S/4GN□RC □— Voltage 24/36/48/110/220
□— Reduction ratio

H4BLD60-□GN-30S/4GN□RT □— Voltage 24/36/48/110/220
□— Reduction ratio

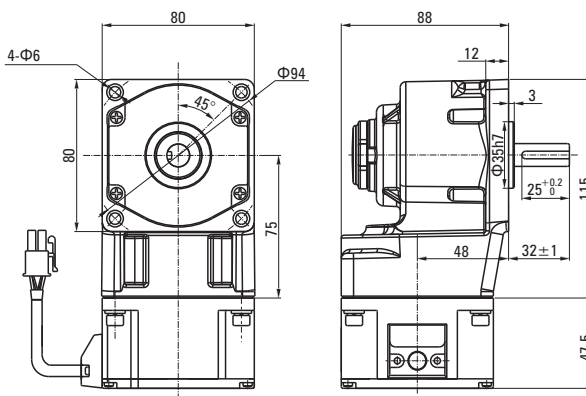
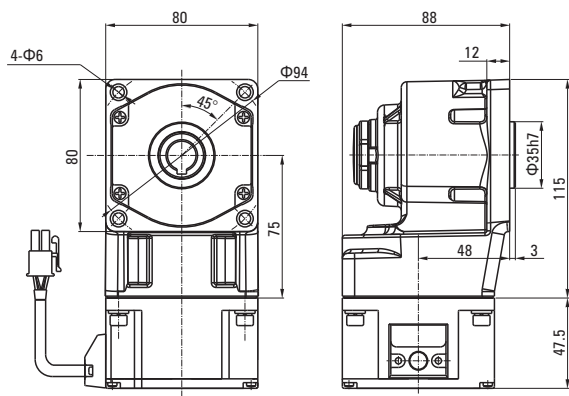

● The output shaft hole structure

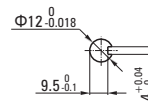
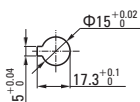

● H4BLD40-□GN-30S/4GN□RC/RT Machine allowable torque (Unit: N.m)

Model	Reduction ratio \ Motor speed	7.5	9	10	12.5	15	18	20	25	30	36	50	60	75	90	100	120	150	180
		H4BLD40-□GN	200~1500RPM	1.21	1.45	1.61	2.01	2.41	2.90	2.90	3.63	4.35	5.22	7.25	7.87	8.00	8.00	8.00	8.00
	2000RPM	1.02	1.23	1.36	1.70	2.04	2.45	2.45	3.07	3.68	4.42	6.13	6.66	8.00	8.00	8.00	8.00	8.00	8.00
	2500RPM	0.93	1.11	1.24	1.55	1.86	2.23	2.23	2.79	3.35	4.02	5.58	6.05	7.56	8.00	8.00	8.00	8.00	8.00
	3000RPM	0.63	0.76	0.84	1.05	1.26	1.51	1.68	2.10	2.52	3.03	4.20	5.58	6.97	8.00	8.00	8.00	8.00	8.00

● H4BLD60-□GN-30S/4GN□RC/RT Machine allowable torque (Unit: N.m)

Model	Reduction ratio \ Motor speed	7.5	9	10	12.5	15	18	20	25	30	36	50	60	75	90	100	120	150	180
		H4BLD60-□GN	200~1500RPM	1.81	2.17	2.41	3.02	3.62	4.34	4.35	5.44	6.53	7.83	8.00	8.00	8.00	8.00	8.00	8.00
	2000RPM	1.53	1.84	2.04	2.55	3.06	3.68	3.68	4.60	5.52	6.63	8.00	8.00	8.00	8.00	8.00	8.00	8.00	8.00
	2500RPM	1.39	1.67	1.86	2.32	2.78	3.34	3.35	4.18	5.02	6.02	8.00	8.00	8.00	8.00	8.00	8.00	8.00	8.00
	3000RPM	0.95	1.13	1.26	1.58	1.89	2.27	2.52	3.15	3.78	4.54	6.30	8.00	8.00	8.00	8.00	8.00	8.00	8.00

Note : The (gray) in the table indicates that the rotation direction is consistent with the motor.
(The torque under different speed and speed ratio is obtained under the HY standard.)

90 SERIES OF BRUSHLESS DC MOTOR (GN TYPE)

Basic characteristics of motor

- 60W (DC power supply is suitable for 24VDC/36VDC/48VDC)

Rated power (Continuous)	W	60 (40W/60W)			
Rated speed	r/min	3000			
Rated torque	N.m	0.191			
Instantaneous maximum torque	N.m	0.287			
Rotor moment of inertia	J: $\times 10^{-4} \text{kg.m}^2$	0.082			
Speed control range	RPM	200~3000			
Speed control range	On load	Below $\pm 1\%$: Condition 0~rated torque, rated speed, rated voltage, room temperature			
	On voltage	Below $\pm 1\%$: Condition rated voltage $\pm 10\%$, rated speed, rated load, room temperature			
	On temperature	Below $\pm 1\%$: Conditions of ambient temperature $-10^\circ\text{C} \sim +40^\circ\text{C}$ rated voltage, rated load and rated speed			
Power input	Rated voltage	V	Single phase 110V	Single phase 220V	24VDC (Optional 36VDC/48VDC)
	Voltage tolerance range		$\pm 10\%$		
	Frequency	Hz	50/60	/	
	Frequency tolerance range		$\pm 5\%$		
	Rated input current	A	1.7	1.0	3.7
	Instantaneous maximum input current	A	3.3	1.9	5.6

Round shaft type only motor

- H5BLD60-A-30S — Voltage 24/36/48/110/220

- H5BLD60-220A-30S
Diagram (HY standard drive)

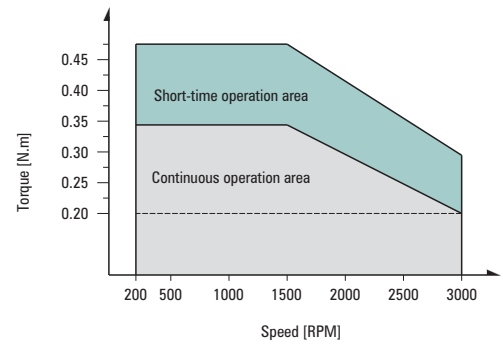
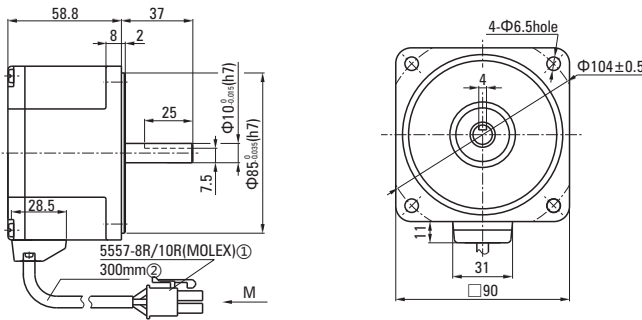

① Connector: 5557-8R/10R (MOLEX) ② Lead wire length 300mm

- Low voltage wire plughole corresponding signal explanation

- High voltage wire plughole corresponding signal explanation

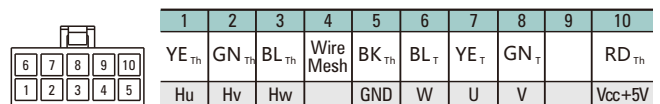
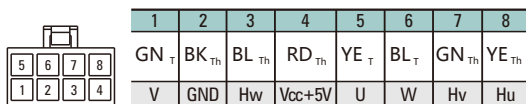

60W

● Parallel shaft gearbox

H5BLD60-□GN-30S/5GN□K □ — Voltage 24/36/48/110/220
 □ — Reduction ratio

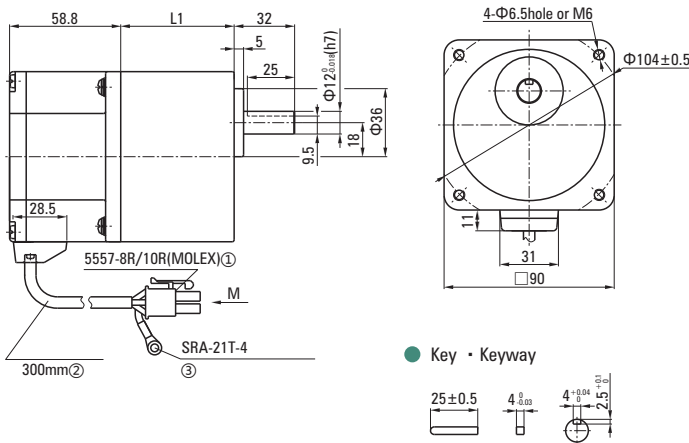

● Decimal gearbox

5GN□XK
 □ — Velocity ratio value, generally 10

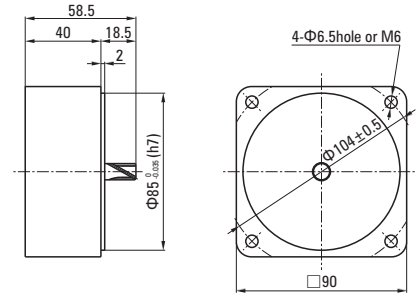

Gearhead model	Gear ratio	Dimension
5GN□K	3~18	42&60
	20~200	60

● □ means gearbox ratio

①Connector: 5557-8R/10R (MOLEX) ②The sheath length of lead line 300mm ③Round terminal: SRA-21T-4 (Low ground)

● H5BLD40-□GN-30S/5GN□K gearmotor allowable torque (Unit: N.m)

Model	Reduction ratio Motor speed	Reduction ratio																							
		3	3.6	5	6	7.5	9	10	12.5	15	18	20	25	30	36	50	60	75	90	100	120	150	180	200	
H5BLD40-□GN	200~1500RPM	0.48	0.58	0.80	0.97	1.21	1.45	1.61	2.01	2.41	2.90	2.90	3.63	4.35	5.22	7.25	7.87	9.83	10.0	10.0	10.0	10.0	10.0	10.0	10.0
	2000RPM	0.41	0.49	0.68	0.82	1.02	1.23	1.36	1.70	2.04	2.45	2.45	3.07	3.68	4.42	6.13	6.66	8.32	9.98	10.0	10.0	10.0	10.0	10.0	10.0
	2500RPM	0.37	0.45	0.62	0.74	0.93	1.11	1.24	1.55	1.86	2.23	2.23	2.79	3.35	4.02	5.58	6.05	7.56	9.08	10.0	10.0	10.0	10.0	10.0	10.0
	3000RPM	0.31	0.37	0.52	0.62	0.77	0.93	1.03	1.29	1.55	1.86	1.86	2.32	2.79	3.35	4.65	5.01	6.26	7.52	8.35	10.0	10.0	10.0	10.0	10.0

● H5BLD60-□GN-30S/5GN□K gearmotor allowable torque (Unit: N.m)

Model	Reduction ratio Motor speed	Reduction ratio																							
		3	3.6	5	6	7.5	9	10	12.5	15	18	20	25	30	36	50	60	75	90	100	120	150	180	200	
H5BLD60-□GN	200~1500RPM	0.72	0.87	1.21	1.45	1.81	2.17	2.41	3.02	3.62	4.34	4.35	5.44	6.53	7.83	9.83	10.0	10.0	10.0	10.0	10.0	10.0	10.0	10.0	10.0
	2000RPM	0.61	0.74	1.02	1.23	1.53	1.84	2.04	2.55	3.06	3.68	3.68	4.60	5.52	6.63	8.32	9.98	10.0	10.0	10.0	10.0	10.0	10.0	10.0	10.0
	2500RPM	0.56	0.67	0.93	1.11	1.39	1.67	1.86	2.32	2.78	3.34	3.35	4.18	5.02	6.02	7.56	9.08	10.0	10.0	10.0	10.0	10.0	10.0	10.0	10.0
	3000RPM	0.46	0.56	0.77	0.93	1.16	1.39	1.55	1.93	2.32	2.78	2.79	3.49	4.18	5.02	6.97	7.52	9.40	10.0	10.0	10.0	10.0	10.0	10.0	10.0

Note : The (Grey background area) in the table indicates that the rotation direction is same as the motor
 (The torque under different speed and speed ratio is obtained under the HY standard.)

90 SERIES OF BRUSHLESS DC MOTOR (GU TYPE)

Basic characteristics of motor

● 120W (DC power supply is suitable for 24VDC/36VDC/48VDC)

Rated power (Continuous)	W	120 (60W/90W/120W)			
Rated speed	r/min	3000			
Rated torque	N.m	0.382			
Instantaneous maximum torque	N.m	0.573			
Rotor moment of inertia	J: 10^{-4} kg.m ²	0.250			
Speed control range	RPM	200~3000			
Speed control range	On load	Below ±1%: Condition 0~rated torque, rated speed, rated voltage, room temperature			
	On voltage	Below±1%: Condition rated voltage ±10%, rated speed, rated load, room temperature			
	On temperature	Below±1%: Conditions of ambient temperature -10°C~+40°C rated voltage, rated load and rated speed			
Power input	Rated voltage	V	Single phase 110V	Single phase 220V	24VDC (Optional 36VDC/48VDC)
	Voltage tolerance range		±10%		
	Frequency	Hz	50/60		/
	Frequency tolerance range		±5%		
	Rated input current	A	3.5	2.0	6.8
Instantaneous maximum input current	A	7.0	4.5	13.0	

Round shaft type only motor

● H5BLD120-A-30S — Voltage 24/36/48/110/220

● H5BLD120-220A-30S
Diagram (HY standard drive)

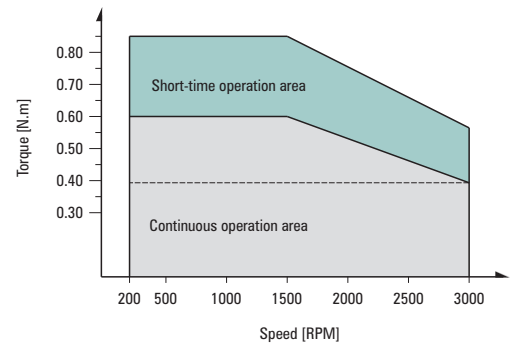
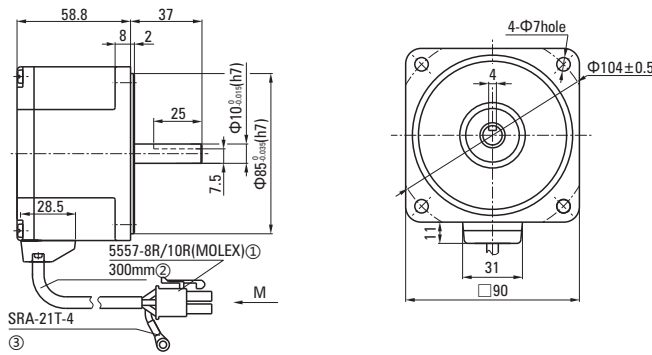

①Connector: 5557-8R/10R (MOLEX) ②Lead wire length 300mm ③Round terminal: SRA-21T-4 (No ground for low voltage)

● Low voltage wire plughole corresponding signal explanation

● High voltage wire plughole corresponding signal explanation

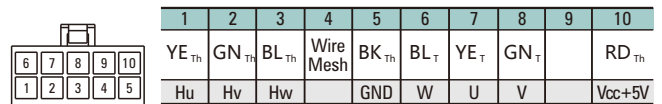
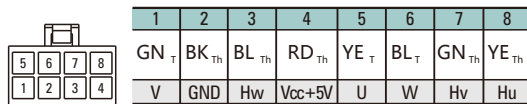

120W

● Parallel shaft gearbox

H5BLD120-GU-30S/5GUKB — Voltage 24/36/48/110/220
 — Reduction ratio

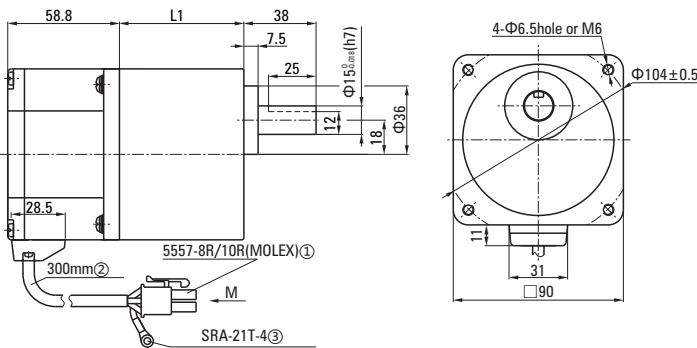

● Key • Keyway



● Decimal gearbox

5GUXK
 — Velocity ratio value, generally 10

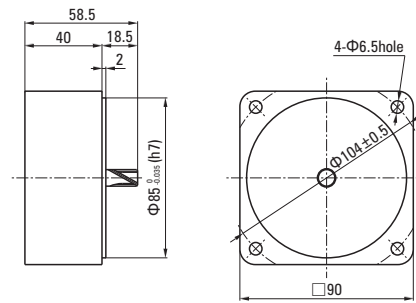

Gearhead model	Gear ratio	Dimension
5GU <input type="checkbox"/> K	3~200	65.5

● means gearbox ratio

①Connector: 5557-8R/10R (MOLEX) ②The sheath length of lead line 300mm ③Round terminal: SRA-21T-4

● H5BLD60-GU-30S/5GUK gearmotor allowable torque (Unit: N.m)

Model	Reduction ratio	Motor speed																							
		3	3.6	5	6	7.5	9	10	12.5	15	18	20	25	30	36	50	60	75	90	100	120	150	180	200	
H5BLD60- <input type="checkbox"/> GU	200~1500RPM	0.72	0.87	1.21	1.45	1.81	2.17	2.41	3.02	3.62	4.34	4.35	5.44	6.53	7.83	9.83	10.0	10.0	10.0	10.0	10.0	10.0	10.0	10.0	10.0
	2000RPM	0.61	0.74	1.02	1.23	1.53	1.84	2.04	2.55	3.06	3.68	3.68	4.60	5.52	6.63	8.32	9.98	10.0	10.0	10.0	10.0	10.0	10.0	10.0	10.0
	2500RPM	0.56	0.67	0.93	1.11	1.39	1.67	1.86	2.32	2.78	3.34	3.35	4.18	5.02	6.02	7.56	9.08	10.0	10.0	10.0	10.0	10.0	10.0	10.0	10.0
	3000RPM	0.46	0.56	0.77	0.93	1.16	1.39	1.55	1.93	2.32	2.78	2.79	3.49	4.18	5.02	6.97	7.52	9.40	10.0	10.0	10.0	10.0	10.0	10.0	10.0

● H5BLD90-GU-30S/5GUK gearmotor allowable torque (Unit: N.m)

Model	Reduction ratio	Motor speed																							
		3	3.6	5	6	7.5	9	10	12.5	15	18	20	25	30	36	50	60	75	90	100	120	150	180	200	
H5BLD90- <input type="checkbox"/> GU	200~1500RPM	1.09	1.30	1.81	2.18	2.72	3.26	3.62	4.53	5.43	6.52	6.53	8.16	9.79	11.8	14.7	17.7	20.0	20.0	20.0	20.0	20.0	20.0	20.0	20.0
	2000RPM	0.92	1.10	1.53	1.84	2.30	2.76	3.06	3.83	4.59	5.51	5.52	6.90	8.28	9.94	12.5	15.0	18.7	20.0	20.0	20.0	20.0	20.0	20.0	20.0
	2500RPM	0.84	1.00	1.39	1.67	2.09	2.51	2.78	3.48	4.18	5.01	5.02	6.27	7.53	9.04	11.3	13.6	17.0	20.0	20.0	20.0	20.0	20.0	20.0	20.0
	3000RPM	0.70	0.84	1.16	1.39	1.74	2.09	2.32	2.90	3.48	4.18	4.18	5.23	6.27	7.53	10.46	11.28	14.1	16.91	18.79	20.0	20.0	20.0	20.0	20.0

● H5BLD120-GU-30S/5GUKB gearmotor allowable torque (Unit: N.m)

Model	Reduction ratio	Motor speed																							
		3	3.6	5	6	7.5	9	10	12.5	15	18	20	25	30	36	50	60	75	90	100	120	150	180	200	
H5BLD120- <input type="checkbox"/> GU	200~1500RPM	1.45	1.74	2.41	2.90	3.62	4.34	4.35	5.44	6.53	7.83	7.87	9.83	11.8	14.2	19.7	20.0	20.0	20.0	20.0	20.0	20.0	20.0	20.0	20.0
	2000RPM	1.23	1.47	2.04	2.45	3.06	3.68	3.68	4.60	5.52	6.63	6.66	8.32	9.98	12.0	16.6	20.0	20.0	20.0	20.0	20.0	20.0	20.0	20.0	20.0
	2500RPM	1.11	1.34	1.86	2.23	2.78	3.34	3.35	4.18	5.02	6.02	6.05	7.56	9.08	10.9	15.1	18.2	20.0	20.0	20.0	20.0	20.0	20.0	20.0	20.0
	3000RPM	0.93	1.11	1.55	1.86	2.32	2.78	3.09	3.87	4.64	5.57	5.58	6.97	8.37	10.04	13.94	15.04	18.79	20.0	20.0	20.0	20.0	20.0	20.0	20.0

Note : The (Grey background area) in the table indicates that the rotation direction is same as the motor (The torque under different speed and speed ratio is obtained under the HY standard.)

- L type gearbox
H5BLD120-GUL-30S/5GULC Voltage 24/36/48/110/220
 Reduction ratio

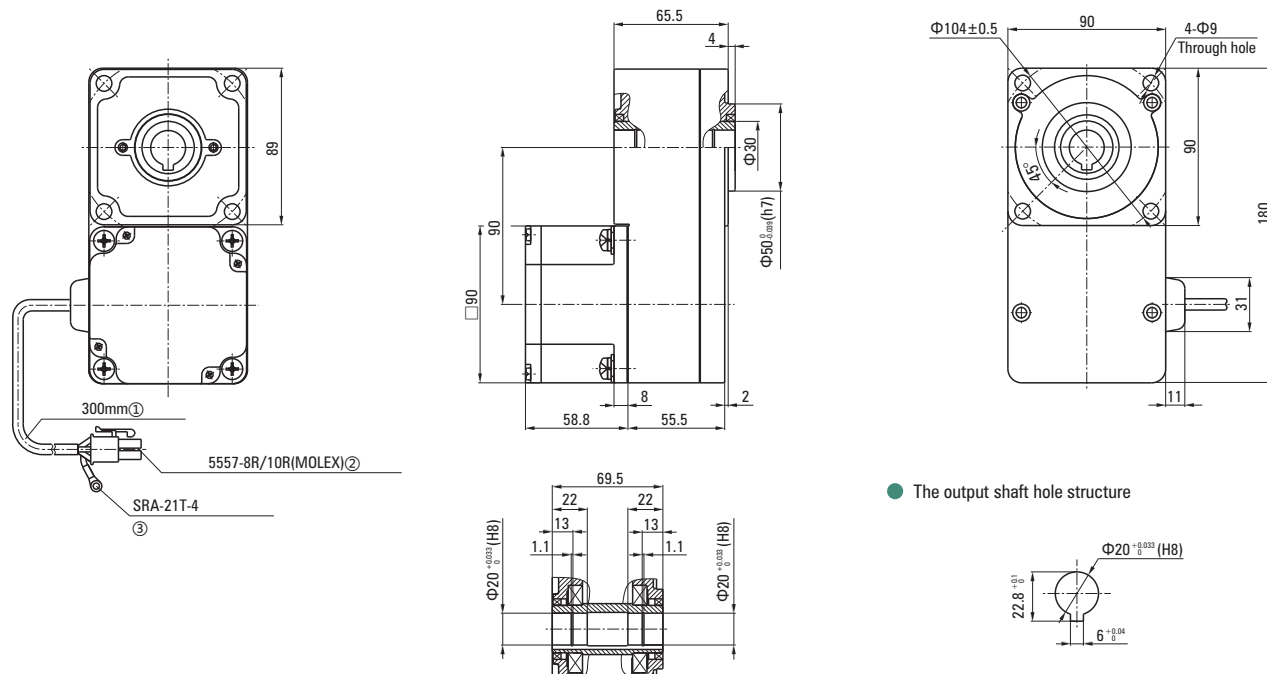

● The output shaft hole structure

①Lead wire length 300mm ②Connector: 5557-8R/10R (MOLEX) ③Round terminal: SRA-21T-4 (No ground for low voltage)

- H5BLD60-GUL-30S/5GULC gearmotor allowable torque (Unit: N.m)

Reduction ratio \ Motor speed	5	10	15	20	30	50	100	200
200~1500RPM	1.09	2.18	3.26	4.35	6.53	10.9	21.8	43.5
2000RPM	0.92	1.84	2.76	3.68	5.52	9.20	18.4	36.8
2500RPM	0.84	1.67	2.51	3.35	5.02	8.37	16.7	33.5
3000RPM	0.70	1.39	2.09	2.79	4.18	6.97	13.94	27.89

- H5BLD90-GUL-30S/5GULC gearmotor allowable torque (Unit: N.m)

Reduction ratio \ Motor speed	5	10	15	20	30	50	100	200
200~1500RPM	1.63	3.26	4.90	6.53	9.79	16.3	32.6	65.3
2000RPM	1.38	2.76	4.14	5.52	8.28	13.8	27.6	55.2
2500RPM	1.25	2.51	3.76	5.02	7.53	12.5	25.1	50.2
3000RPM	1.05	2.09	3.14	4.18	6.27	10.46	20.91	41.83

- H5BLD120-GUL-30S/5GULC gearmotor allowable torque (Unit: N.m)

Reduction ratio \ Motor speed	5	10	15	20	30	50	100	200
200~1500RPM	2.41	4.83	7.24	9.65	13.1	21.8	43.5	68.0
2000RPM	2.04	4.08	6.13	8.17	11.0	18.4	36.8	66.6
2500RPM	1.86	3.71	5.57	7.43	10.0	16.7	33.5	60.5
3000RPM	1.39	2.79	4.18	5.58	8.37	13.94	27.89	55.77

Note : All gearbox output turn direction in form are opposite motor turn direction.
(The torque under different speed and speed ratio is obtained under the HY standard.)

● Arc cone right angle speed reducer motor

H5BLD120-GU-30S/5GURC — Voltage 24/36/48/110/220
— Reduction ratio

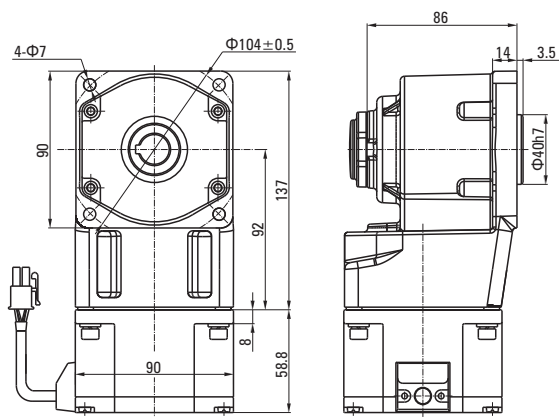

H5BLD120-GU-30S/5GURT — Voltage 24/36/48/110/220
— Reduction ratio

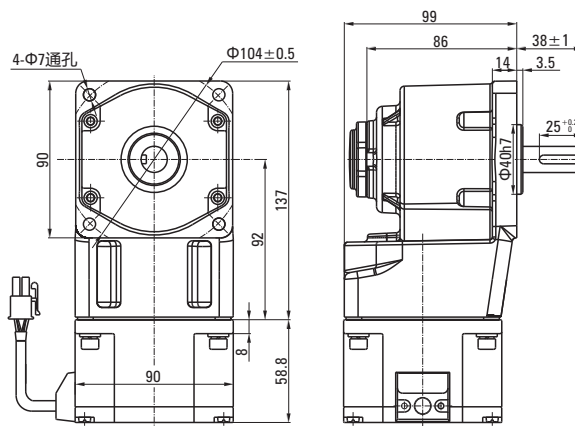

● The output shaft hole structure

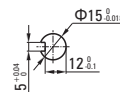
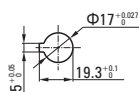

● H5BLD60-GU-30S/5GURC/RT gearmotor allowable torque (Unit: N.m)

Model	Reduction ratio	Motor speed																	
		7.5	9	10	12.5	15	18	20	25	30	36	50	60	75	90	100	120	150	180
H5BLD60- <input checked="" type="checkbox"/> GU	200~1500RPM	1.81	2.17	2.41	3.02	3.62	4.34	4.35	5.44	6.53	7.83	9.83	10.0	10.0	10.0	10.0	10.0	10.0	10.0
	2000RPM	1.53	1.84	2.04	2.55	3.06	3.68	3.68	4.60	5.52	6.63	8.32	9.98	10.0	10.0	10.0	10.0	10.0	10.0
	2500RPM	1.39	1.67	1.86	2.32	2.78	3.34	3.35	4.18	5.02	6.02	7.56	9.08	10.0	10.0	10.0	10.0	10.0	10.0
	3000RPM	0.95	1.13	1.26	1.58	1.89	2.27	2.52	3.15	3.78	5.02	6.97	8.37	10.0	10.0	10.0	10.0	10.0	10.0

● H5BLD90-GU-30S/5GURC/RT gearmotor allowable torque (Unit: N.m)

Model	Reduction ratio	Motor speed																	
		7.5	9	10	12.5	15	18	20	25	30	36	50	60	75	90	100	120	150	180
H5BLD90- <input checked="" type="checkbox"/> GU	200~1500RPM	2.72	3.26	3.62	4.53	5.43	6.52	6.53	8.16	9.79	11.8	14.7	17.7	20.0	20.0	20.0	20.0	20.0	20.0
	2000RPM	2.30	2.76	3.06	3.83	4.59	5.51	5.52	6.90	8.28	9.94	12.5	15.0	18.7	20.0	20.0	20.0	20.0	20.0
	2500RPM	2.09	2.51	2.78	3.48	4.18	5.01	5.02	6.27	7.53	9.04	11.3	13.6	17.0	20.0	20.0	20.0	20.0	20.0
	3000RPM	1.42	1.70	1.89	2.36	2.84	3.40	3.78	4.73	5.67	7.53	10.46	12.55	15.69	18.82	20.0	20.0	20.0	20.0

● H5BLD120-GU-30S/5GURC/RT gearmotor allowable torque (Unit: N.m)

Model	Reduction ratio	Motor speed																	
		7.5	9	10	12.5	15	18	20	25	30	36	50	60	75	90	100	120	150	180
H5BLD120- <input checked="" type="checkbox"/> GU	200~1500RPM	3.62	4.34	4.35	5.44	6.53	7.83	7.87	9.83	11.8	14.2	19.7	20.0	20.0	20.0	20.0	20.0	20.0	20.0
	2000RPM	3.06	3.68	3.68	4.60	5.52	6.63	6.66	8.32	9.98	12.0	16.6	20.0	20.0	20.0	20.0	20.0	20.0	20.0
	2500RPM	2.78	3.34	3.35	4.18	5.02	6.02	6.05	7.56	9.08	10.9	15.1	18.2	20.0	20.0	20.0	20.0	20.0	20.0
	3000RPM	1.89	2.27	2.52	3.15	3.78	4.54	5.04	6.30	7.56	10.04	13.94	16.73	20.0	20.0	20.0	20.0	20.0	20.0

Note : The (Grey background area) in the table indicates that the rotation direction is same as the motor
 (The torque under different speed and speed ratio is obtained under the HY standard.)

104 SERIES OF BRUSHLESS DC MOTOR

Basic characteristics of motor

● 200W (DC power supply is suitable for 24VDC/36VDC/48VDC)

Rated power (Continuous)	W	200 (200W/400W)			
Rated speed	r/min	3000			
Rated torque	N.m	0.636			
Instantaneous maximum torque	N.m	0.955			
Rotor moment of inertia	J:10 ⁻⁴ kg.m ²	0.460			
Speed control range	RPM	High pressure 200-2500RPM (Low pressure 200-3000RPM)			
Speed control range	On load	Below ±1%: Condition 0~rated torque, rated speed, rated voltage, room temperature			
	On voltage	Below±1%: Condition rated voltage ±10%, rated speed, rated load, room temperature			
	On temperature	Below±1%: Conditions of ambient temperature -10°C~+40°C rated voltage, rated load and rated speed			
Power input	Rated voltage	V	Single phase 110V	Single phase 220V	36VDC (Optional 48VDC)
	Voltage tolerance range		±10%		
	Frequency	Hz	50/60		/
	Frequency tolerance range		±5%		
	Rated input current	A	4.7	2.4	7.5
Instantaneous maximum input current	A	9.0	4.8	11.5	

Round shaft type only motor

● H6BLD200-A-30S — Voltage 24/36/48/110/220

● H6BLD200-220A-30S
Diagram (HY standard drive)

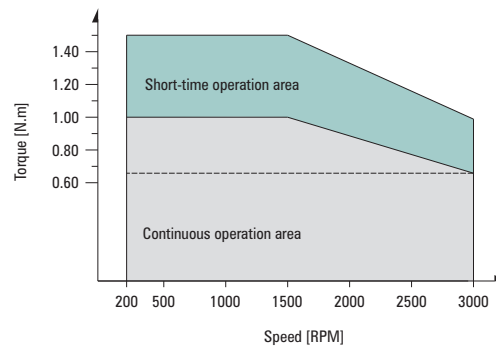
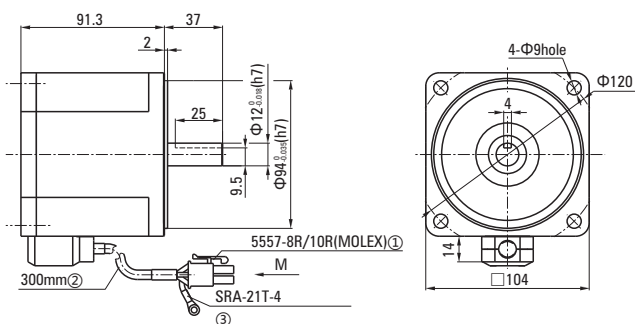

①Connector: 5557-8R/10R (MOLEX) ②Lead wire length 300mm ③Round terminal: SRA-21T-4 (No ground for low voltage)

● Low voltage wire plughole corresponding signal explanation

● High voltage wire plughole corresponding signal explanation

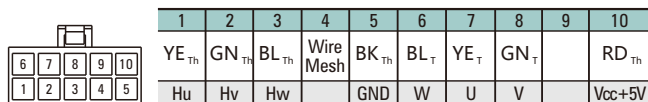
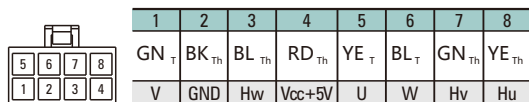

200W

Parallel shaft gearbox

H6BLD200-□GU-30S/6GU□K □ — Voltage 24/36/48/110/220
 □ — Reduction ratio

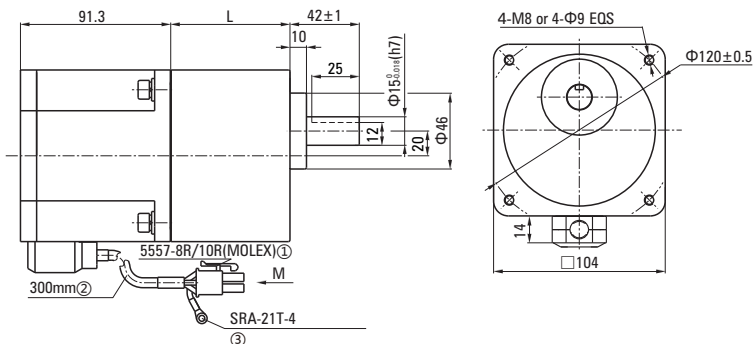

● Key · Keyway

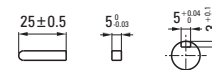

Gearhead model	Gear ratio	Dimension
6GU□K	3~200	72

● □ means gearbox ratio

①Connector: 5557-8R/10R (MOLEX) ②The length of lead line 300mm ③Round terminal: SRA-21T-4 (No ground for low voltage)

H6BLD200-□GU-30S/6GU□K gearmotor allowable torque (Unit: N.m)

Model	Reduction ratio Motor speed	Reduction ratio																					
		3	3.6	5	6	7.5	9	12.5	15	18	25	30	36	50	60	75	90	100	120	150	180	200	
H6BLD200-□GU	200~1500RPM	2.41	2.90	4.02	4.83	6.03	7.24	9.06	10.9	13.1	16.4	19.7	23.6	32.8	39.3	40.0	40.0	40.0	40.0	40.0	40.0	40.0	40.0
	2000RPM	2.04	2.45	3.40	4.08	5.11	6.13	7.67	9.20	11.0	13.9	16.6	20.0	27.7	33.3	40.0	40.0	40.0	40.0	40.0	40.0	40.0	40.0
	2500RPM	1.86	2.23	3.09	3.71	4.64	5.57	6.97	8.37	10.0	12.6	15.1	18.2	25.2	30.3	37.8	40.0	40.0	40.0	40.0	40.0	40.0	40.0
	3000RPM	1.55	1.86	2.58	3.09	3.87	4.64	5.81	6.97	8.37	10.44	12.53	15.04	20.88	25.06	31.32	37.59	40.0	40.0	40.0	40.0	40.0	40.0

H6BLD400-□GU-30S/6GU□K gearmotor allowable torque (Unit: N.m)

Model	Reduction ratio Motor speed	Reduction ratio																					
		3	3.6	5	6	7.5	9	12.5	15	18	25	30	36	50	60	75	90	100	120	150	180	200	
H6BLD400-□GU	200~1500RPM	4.82	5.80	8.04	9.66	12.06	14.48	18.12	21.8	26.2	32.8	39.4	40.0	40.0	40.0	40.0	40.0	40.0	40.0	40.0	40.0	40.0	40.0
	2000RPM	4.08	4.90	6.80	8.16	10.22	12.26	15.34	18.4	22.0	27.8	33.2	40.0	40.0	40.0	40.0	40.0	40.0	40.0	40.0	40.0	40.0	40.0
	2500RPM	3.72	4.46	6.18	7.42	9.28	11.14	13.94	16.74	20.0	25.2	30.2	36.4	40.0	40.0	40.0	40.0	40.0	40.0	40.0	40.0	40.0	40.0
	3000RPM	3.09	3.71	5.16	6.19	7.74	9.28	11.62	13.94	16.73	20.88	25.06	30.07	40.0	40.0	40.0	40.0	40.0	40.0	40.0	40.0	40.0	40.0

Note : The (Grey background area) in the table indicates that the rotation direction is same as the motor
 (The torque under different speed and speed ratio is obtained under the HY standard.)

L type gearbox

H6BLD200-□GUL-30S/6GU□LC □ — Voltage 24/36/48/110/220
 □ — Reduction ratio

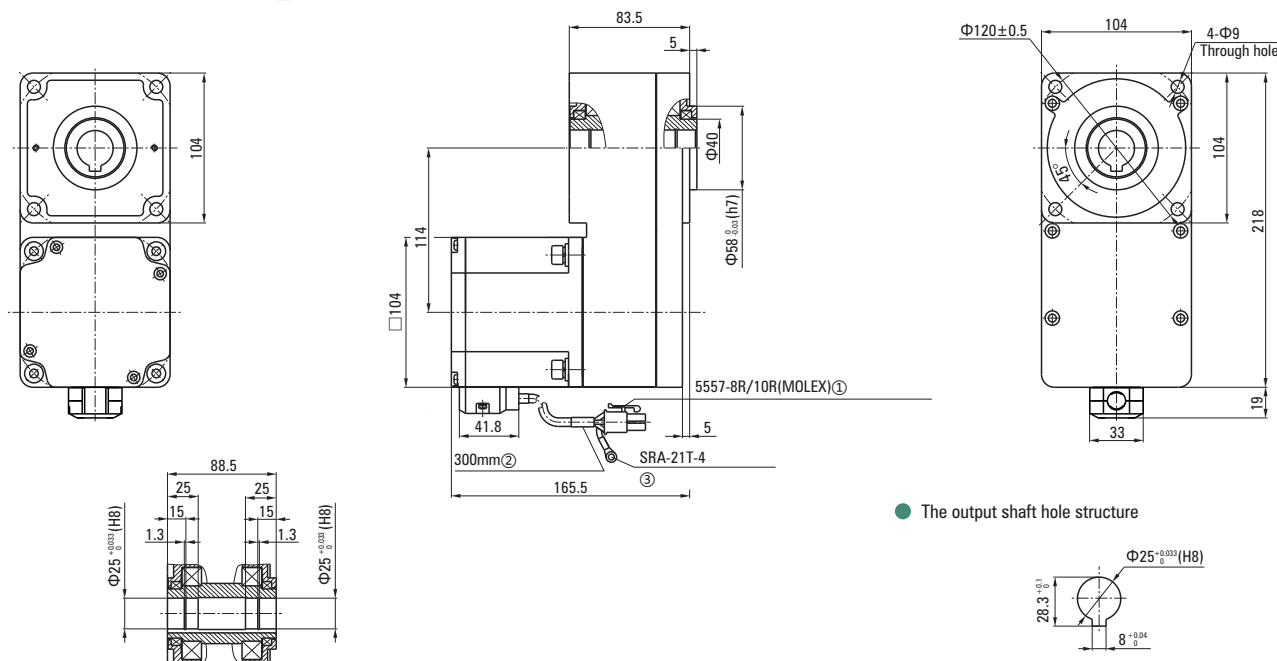

● The output shaft hole structure

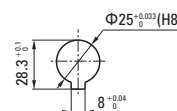

①Connector: 5557-8R/10R (MOLEX) ②Lead wire length 300mm ③Round terminal: SRA-21T-4 (No ground for low voltage)

H6BLD200- GUL-30S/6GU□LC gearmotor allowable torque (Unit: N.m)

Reduction ratio / Motor speed	Reduction ratio						
	5	15	20	30	40	50	100
200~1500RPM	4.02	12.1	16.10	21.80	32.20	40.20	80.40
2000RPM	3.40	10.2	13.60	20.40	27.20	34.00	68.00
2500RPM	3.09	9.27	12.36	18.54	24.72	30.90	61.80
3000RPM	2.32	6.96	9.280	13.92	18.56	23.20	46.40

H6BLD400- GUL-30S/6GU□LC gearmotor allowable torque (Unit: N.m)

Reduction ratio / Motor speed	Reduction ratio						
	5	15	20	30	40	50	100
200~1500RPM	8.04	24.20	32.20	43.60	64.40	80.40	120.0
2000RPM	6.80	20.40	27.20	40.80	54.40	68.00	120.0
2500RPM	6.18	18.54	24.72	37.08	49.44	61.80	120.0
3000RPM	4.64	13.92	18.56	27.84	37.12	46.40	92.80

Note : All gearbox output turn direction in form are opposite motor turn direction.
(The torque under different speed and speed ratio is obtained under the HY standard.)

Arc cone right angle speed reducer motor

H6BLD200- GUL-30S/6GU□RC □— Voltage 24/36/48/110/220
□— Reduction ratio

H6BLD200- GUL-30S/6GU□RT □— Voltage 24/36/48/110/220
□— Reduction ratio

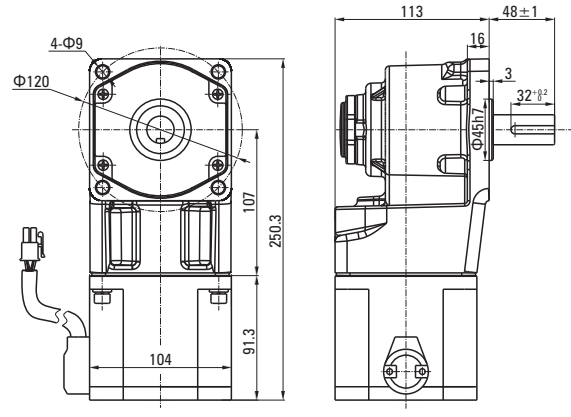
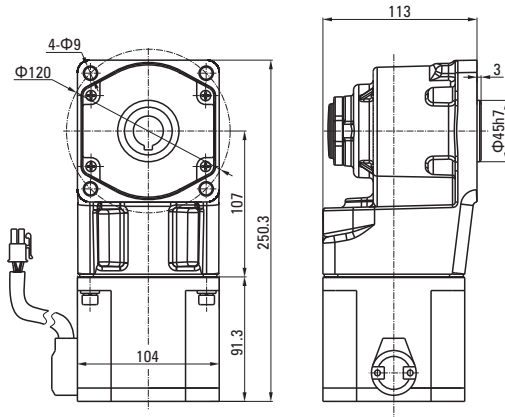

The output shaft hole structure

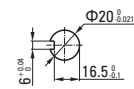
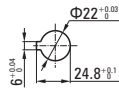

H6BLD200- GU-30S/6GU□RC/RT gearmotor allowable torque (Unit: N.m)

Model	Reduction ratio / Motor speed	Reduction ratio																	
		7.5	9	12.5	15	18	25	30	36	50	60	75	90	100	120	150	180	200	
H6BLD200- GUL	200~1500RPM	6.03	7.24	9.06	10.9	13.1	16.4	19.7	23.6	32.8	39.3	40.0	40.0	40.0	40.0	40.0	40.0	40.0	40.0
	2000RPM	5.11	6.13	7.67	9.20	11.0	13.9	16.6	20.0	27.7	33.3	40.0	40.0	40.0	40.0	40.0	40.0	40.0	40.0
	2500RPM	4.64	5.57	6.97	8.37	10.0	12.6	15.1	18.2	25.2	30.3	37.8	40.0	40.0	40.0	40.0	40.0	40.0	40.0
	3000RPM	3.15	3.78	5.25	6.30	7.56	10.51	12.61	15.13	23.24	27.89	34.86	40.0	40.0	40.0	40.0	40.0	40.0	40.0

H6BLD400- GU-25S/6GU□RC/RT gearmotor allowable torque (Unit: N.m)

Model	Reduction ratio / Motor speed	Reduction ratio																	
		7.5	9	12.5	15	18	25	30	36	50	60	75	90	100	120	150	180	200	
H6BLD400- GUL	200~1500RPM	12.06	14.48	18.12	21.8	26.2	32.8	39.4	40.0	40.0	40.0	40.0	40.0	40.0	40.0	40.0	40.0	40.0	40.0
	2000RPM	10.22	12.26	15.34	18.4	22.0	27.8	33.2	40.0	40.0	40.0	40.0	40.0	40.0	40.0	40.0	40.0	40.0	40.0
	2500RPM	9.28	11.14	13.94	16.74	20.0	25.2	30.2	36.4	40.0	40.0	40.0	40.0	40.0	40.0	40.0	40.0	40.0	40.0
	3000RPM	6.30	7.56	10.51	12.61	15.13	21.01	25.21	30.25	40.0	40.0	40.0	40.0	40.0	40.0	40.0	40.0	40.0	40.0

Note : The (Grey background area) in the table indicates that the rotation direction is same as the motor
(The torque under different speed and speed ratio is obtained under the HY standard.)

86 SERIES OF BRUSHLESS DC MOTOR (GU TYPE)

Parallel shaft gearbox

H55BLD200-GUL-30S/5GULC — Voltage 24/36/48
— Reduction ratio

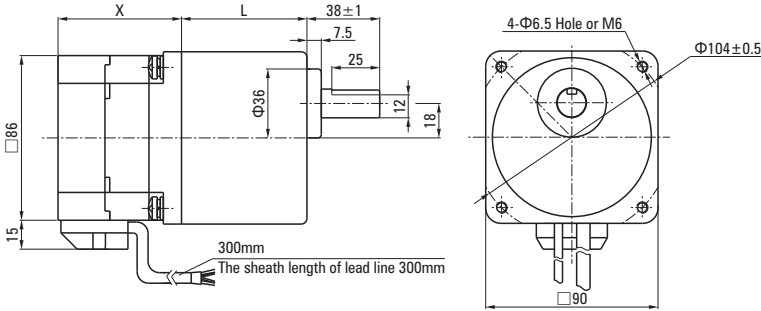

Key · Keyway



L type gearbox

H55BLD200-GUL-30S/5GULC — Voltage 24/36/48
— Reduction ratio

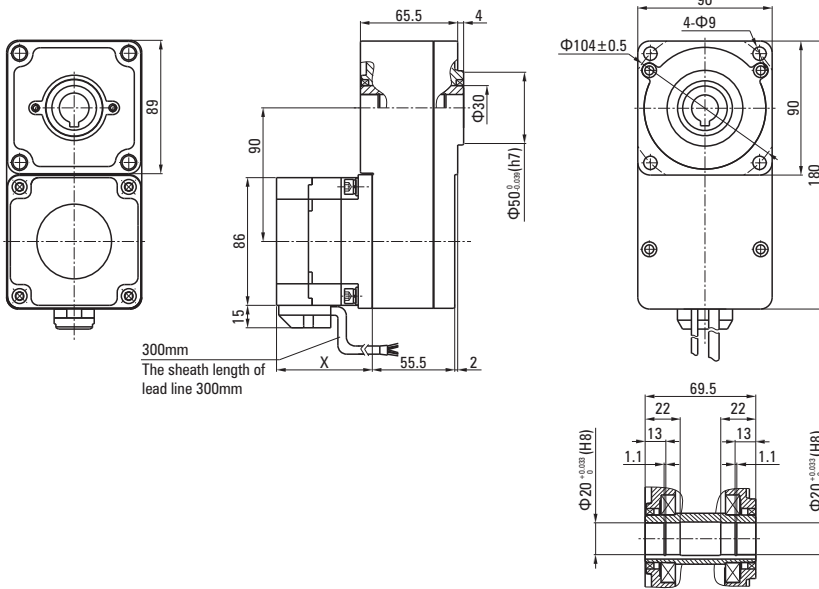

Motor power band

Rated power	Rated speed	Extent
200	3000	64.5
300	3000	74.5
400	3000	84.5
500	3000	94.5
600	3000	105.5
750	3000	130.0

Gearhead model	Gear ratio	Dimension
5GU <input type="checkbox"/> KB	3~200	65.5

means gearbox ratio

Decimal gearbox

5GUXK
—Velocity ratio value, generally 10

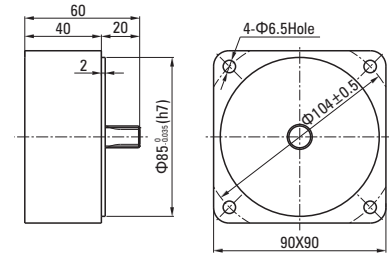

The output shaft hole structure

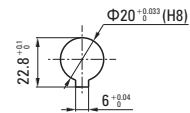

120 SERIES OF BRUSHLESS DC MOTOR (GU TYPE)

750W

- Parallel shaft gearbox
H7BLD750-GV-30S/7GUV — Voltage 48/220
— Reduction ratio

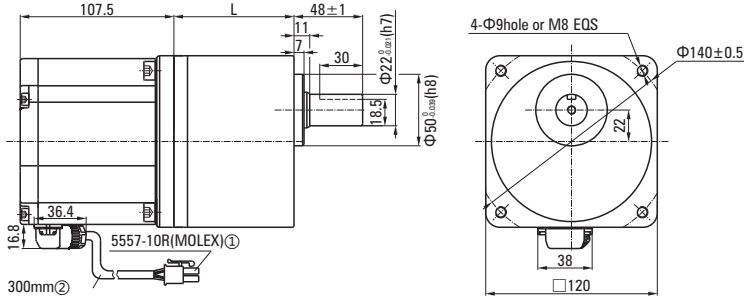

- Key · Keyway

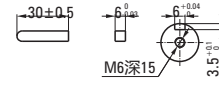

Gearhead model	Gear ratio	Dimension
7GU <input type="checkbox"/> V	5~50	84

- means gearbox ratio

①Connector: 5557-10R (MOLEX) ②The sheath length of lead line 300mm

- H7BLD750-GV-30S/7GUV gearmotor allowable torque (Unit: N.m)

Model	Motor speed	Reduction ratio						
		5	10	15	20	30	50	
H7BLD750- <input type="checkbox"/> GV	200~1500RPM	19.34	38.68	52.29	69.72	100.00	100.00	
	2000RPM	14.50	29.01	39.21	52.29	78.43	100.00	
	2500RPM	11.60	23.21	31.37	41.83	62.74	100.00	
	3000RPM	9.67	19.34	26.14	34.86	52.29	87.14	

- H7BLD750-GUL-30S/7GUL gearmotor allowable torque (Unit: N.m)

Model	Motor speed	Reduction ratio							
		5	10	15	20	25	30	50	100
H7BLD750- <input type="checkbox"/> GUL	200~1500RPM	17.43	34.86	52.29	69.72	87.14	104.57	174.00	200.00
	2000RPM	13.07	26.14	39.21	52.29	65.36	78.43	130.72	200.00
	2500RPM	10.46	20.91	31.37	41.83	52.29	62.74	104.57	200.00
	3000RPM	8.71	17.43	26.14	34.86	43.57	52.29	87.14	174.00

Note : The (Grey background area) in the table indicates that the rotation direction is same as the motor
(The torque under different speed and speed ratio is obtained under the HY standard.)

- L type gearbox
H7BLD750-GUL-30S/7GUL — Voltage 48/220 — Reduction ratio

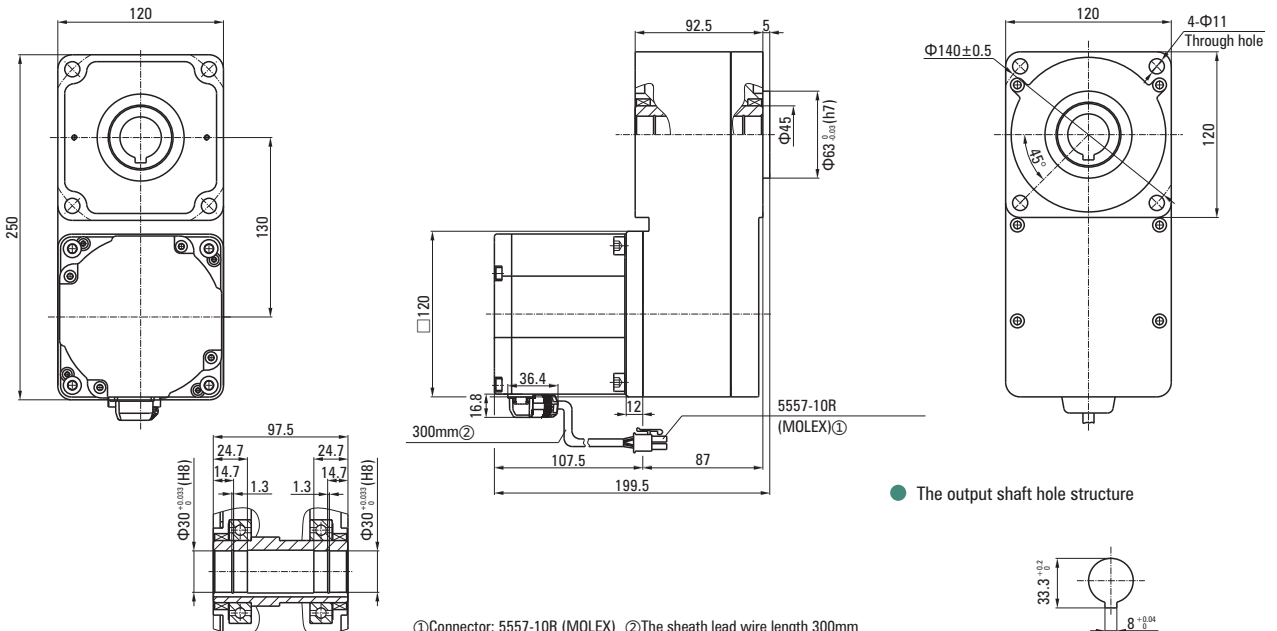

- The output shaft hole structure

①Connector: 5557-10R (MOLEX) ②The sheath lead wire length 300mm

● Arc cone right angle speed reducer motor

H7BLD750/1100-GUR-30S/7GURC Voltage 48/220
 Reduction ratio

H7BLD750/1100-GUR-30S/7GURT Voltage 48/220
 Reduction ratio

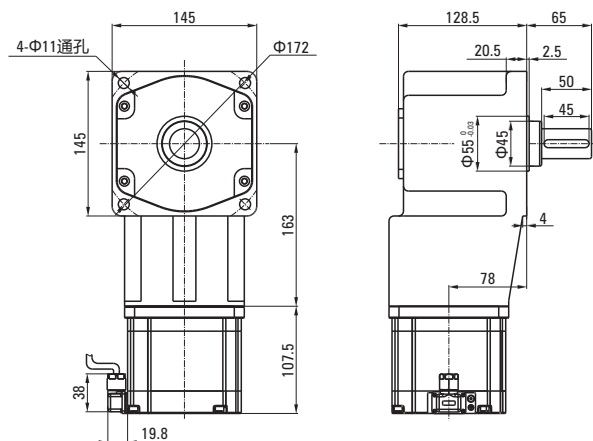
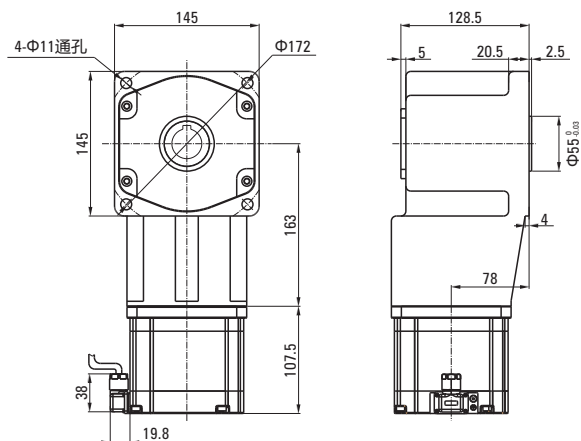

● The output shaft hole structure

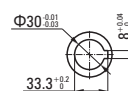
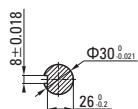

● H7BLD750-GUR-30S/7GURC/RT gearmotor allowable torque (Unit: N.m)

Model	Reduction ratio / Motor speed	5	10	15	20	25	30	50	100
		H7BLD750- <input checked="" type="checkbox"/> GUR	100-2000r/min	11.75	26.11	39.16	52.21	65.27	78.32
	3000r/min	7.83	17.40	26.11	34.81	43.51	52.21	78.32	156.64

Note : The color represents the same direction as the rotation direction of the motor. Others are in the opposite direction.

● H7BLD1100-GUR-30S/7GURC/RT gearmotor allowable torque (Unit: N.m)

Model	Reduction ratio / Motor speed	5	10	15	20	25	30	50	100
		H7BLD1100- <input checked="" type="checkbox"/> GUR	100-2000r/min	17.23	38.29	57.44	76.58	95.73	114.87
	3000r/min	11.49	25.53	38.29	51.05	63.82	76.58	114.87	229.74

Note : The color represents the same direction as the rotation direction of the motor. Others are in the opposite direction.

C10 SERIES BRUSHLESS DRIVERS

H BLD • C10 — 120 L/H/S2 D/X
① ② ③ ④ ⑤ ⑥

①	Company	HY MOTOR	
②	Type	BLD: Motor driver	
		DRV: Driver and related products	
③	Version	C10: C10、C13 Series	
④	Power	120	200
		120W	200W
⑤	Voltage	L: DC24V~48V Low voltage	L2: DC24V Low voltage
		H/S2: High voltage AC220V/50Hz	
⑥	Feature	D: With display	
		X: With extended function	

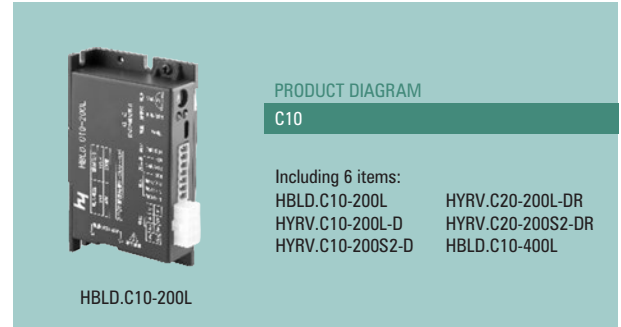

HYRV.C10-200S2-D



HYRV.C20-200L-DR



HYRV.C20-200S2-DR



● HYRV.C13-90L2



● HYRV.C13-120S2

Features of C10 series brushless motor driver

- Digital display: 4-digit digital tube display: running status, set speed, running speed, fault indication.
- Stable speed operation: adopt speed closed-loop control (control accuracy $\pm 0.5\%$).
- Input and output: 2 groups of NPN type digital input interfaces (forward and reverse); 1 group of open-drain digital output interfaces (fault output).
- Speed setting: Set the running speed through the panel knob, which is convenient and quick.
- Perfect fault detection and protection functions: 1. Various fault detections such as undervoltage, overvoltage, overcurrent, overload, locked rotor, short circuit, phase loss, overtemperature, etc.; 2. After the failure occurs, the drive carries out corresponding protection actions according to the type of failure; 3. The fault information can be displayed through the digital tube.
- Extended functions include: expansion of 3 sets of NPN digital input interfaces, 1 set of analog quantity interfaces, and 1 set of 485 communication control interfaces.

C20 SERIES BRUSHLESS DRIVERS

H BLD • C20 — 120 L/H/S2 C/R
① ② ③ ④ ⑤ ⑥

①	Company	HY MOTOR		
②	Type	BLD: Brushless driver		
		DRV: Driver and related products		
③	Version	C20: C20 Series		
④	Power	120	400	800
		120W	400W	800W
⑤	Voltage	L: DC24V~48V (L1:12V; L2:24V; L3:36V; L4:48V)		
		H/S2: High voltage AC220V		
⑥	Feature	C: CAN Can communication		
		R: 485 communication		

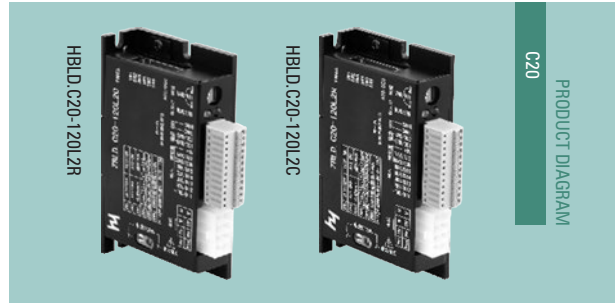

Features of C20 series brushless motor driver

- A variety of operating modes: open-loop, closed-loop (control accuracy $\pm 0.5\%$).
- Multiple commands given: multi-function input terminal control, communication control, external keyboard control.
- Various speed settings: built-in knob, external analog voltage (0~5/10V) or PWM (3k~10kHz), HDI high-speed pulse input 0~20KHZ frequency setting, communication setting, keyboard setting, multi-speed, Simple PLC control (depending on the specific model).
- Acceleration/deceleration control: 0.3s~10s range, can be adjusted by knob, communication adjustment and keyboard adjustment.
- Electronic brake function: realize fast electromagnetic braking.
- Multi-function input interface: 5 digital inputs, which can be customized by the user through the keyboard: forward, reverse, jog, free stop, electronic brake, multi-speed and other functional inputs.
- Multi-function output interface: 2 digital outputs can be customized by the user through the keyboard: running, fault, speed output, overload warning, virtual terminal output and other functional outputs.
- Perfect fault detection and protection functions: under-voltage, over-voltage, over-current, overload, locked-rotor, short-circuit, phase-loss, over-temperature and other fault detection; after a fault occurs, the driver performs corresponding protection actions according to the type of fault; Fault information can be displayed by LED lights or keyboard.

Keyboard accessories: The external keyboard can be used to set parameters, read status, realize keyboard control, multi-function input, multi-function output, multi-speed, simple PLC and other functions.

C30 SERIES BRUSHLESS DRIVERS

H DRV • C30 — 200 L/S2 B/C/R
① ② ③ ④ ⑤ ⑥

①	Company	HY MOTOR		
②	Type	DRV: Driver and related products		
③	Version	C30: C30 Series		
④	Power	120	200	400
		120W	200W	400W
⑤	Voltage	L: DC24V~48V (L1:12V; L2:24V; L3:36V; L4:48V)		
		S2: High voltage AC220V		
⑥	Feature	B: With brake		
		R: With 485 communication		
		C: CAN With Can communication		
		D: With display		



● HYRV.C30-120S2-DR



● HYRV.C30-400S2-DR



● HYRV.C30-200L-BCR



● HYRV.C30-400L-BCR



Features of C30 series brushless motor driver

- Multiple operation modes: open-loop, closed-loop (control accuracy $\pm 0.5\%$).
- Multiple control modes: four-quadrant operation, zero-speed hold, torque/speed mode, zero-speed positioning.
- A variety of command given: multi-function input terminal control (support NPN, PNP input); communication control; external keyboard control.
- Various speed settings: built-in knob, external analog voltage (0~5/10V) or PWM (3k~10kHz), HDI high-speed pulse input 0~20KHZ frequency setting, communication setting, keyboard setting, multi-speed, Simple PLC control (depending on the specific model).
- Acceleration/deceleration control: 0.3s~10s can be adjusted by communication and keyboard.
- Electronic brake function: realize fast electromagnetic braking, and external energy consumption resistance braking can be realized.
- Multi-function input interface: 5 digital inputs (supports NPN and PNP), which can be customized by the user through the keyboard: forward, reverse, jog, free stop, electronic brake, multi-speed and other functional inputs.
- Multi-function output interface: 2 digital outputs can be customized by the user through the keyboard: running, fault, speed output, overload warning, virtual terminal output and other functional outputs.
- Perfect fault detection and protection functions: under-voltage, over-voltage, over-current, overload, locked rotor, short-circuit, lack of etc. fault detection; after a fault occurs, the driver will perform corresponding protection actions according to the type of fault; fault information can be passed through LED lights or keyboard display.

COMMON SPECIFICATIONS

Permissible overhung load and permissible thrust load of motor

Permissible overhung load

Motor		Permissible overhung load	
Motor frame size □(mm)	Output shaft diameter □(mm)	Distance from shaft end	
		10mm	20mm
42	5	40	-
60	6	50	110
70	6	40	60
80	8	90	140
	10	110	120
90	10	140	200
	12	240	270
100	14	320	350

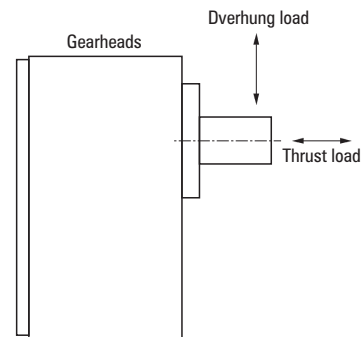

- Permissible thrust load.
- Avoid thrust loads as much as possible. If thrust load is unavoidable, keep it to half or less of the motor mass.

Allowable suspension load of motor • Allowable axial load

Model	Gear ratio	Maximum permissible torque N.m	Permissible overhung load N		Permissible thrust load N
			10mm from shaft end	20mm from shaft end	
2GN□K	3~18	3.0	50	80	30
	25~200		120	180	
4GN□K	3~18	8.0	100	150	50
	25~200		200	300	
5GN□K	3~18	10	250	350	100
	25~200		300	450	
5GU□KB 5GU□K	3~9	20	400	500	150
	12.5~18		450	600	
	25~200		500	700	
6GU□K	3~200	40	1100	1500	300

Permissible load inertia for gearhead J

- When a high load inertia (J) is connected to a gearhead, high torque is exerted instantaneously on the gearhead when starting up in frequent, discontinuous operations (or when stopped by an electromagnetic brake, or when stopped instantaneously by a brake pack). Excessive impact loads can cause the gearhead or motor damage.
- The table below gives values for permissible load inertia on the motor shaft. Use the motor and gearhead within these parameters. The permissible inertial load value shown for three-phase motors is the value when reversing after a stop.
- The permissible load inertia (J) on the gearhead output shaft is calculated with the following equation.
- The life of the gearhead when operating at the permissible inertial load with instantaneous stops of the motors with electromagnetic brakes, brake packs or speed control motors is at least 2 million cycles.

Permissible load inertia for gear head output shaft

Gear ratio 1/3 ~ 1/50 JG=JM×1

JG: Permissible load inertia gearhead output shaft J (×10kg.m²)

Gear ratio 1/60 or high JG=JM×2500

JM: Permissible load inertia at the motor shaft J (×10kg.m²) i:

Gear ratio (Example: i=3 means the gear ratio or 1/3)

Permissible load inertia at the motor shaft

No. of phase	Motor frame size	Output power	Permissible load inertia at the motor shaft	
			J(×10 ⁻⁴ kg.m ²)	GD ² (kg.m ²)
Single-phase	42	1W, 3W	0.016	0.07
	60	3W※, 6W	0.062	0.25
	70	6W※, 15W	0.14	0.52
	80	10W※, 25W	0.31	1.2
	90	20W※, 40W	0.75	3
		60W	1.1	4.6
		90W	1.1	4.6
	100	120W	1.1	4.6
		120W	2	8
		140W	2	8
Three-phase	60	6W	0.062	0.25
	70	15W	0.14	0.52
	80	25W	0.31	1.2
	90	40W	0.75	3
		60W	1.1	4.6
		90W	1.1	4.6
	100	120W	1.1	4.6
		120W	2	8
		140W	2	8
		180W	2	8
DC Power	60	6W, 10W, 15W	0.062	0.25
	70	15W	0.14	0.52
	80	25W, 40W	0.31	1.2
	90	40W	0.75	3
		60W	1.1	4.6
		90W	1.1	4.6
	100	120W	1.1	4.6
		250W	2	8

※Output power for torque motors

The calculation for the permissible torque of gearhead

Permissible torque for some products are omitted. In that case, use the equation below to calculate the permissible torque.

Permissible torque $TG = TM \times i \times \eta$

TG: Permissible torque of gearhead

TM: Motor torque

i: Gear ratio gearhead

 η : Gearhead efficiency

Gearhead efficiency

Model	Gear ratio																			
	3	3.6	5	6	7.5	9	12.5	15	18	25	30	36	50	60	75	90	100	120	150	180
2GN□K	81%											73%			66%					
4GN□K 4GN□RC/RT	81%											73%			66%					
5GN□K	81%											73%			66%					
5GU□KB 5GU□RC/RT	81%											73%			66%					
6GU□K 6GU□RC/RT	81%											73%			66%					

Model	Gear ratio							
	5	10	15	20	30	50	100	200
2GN□L	83%	89%						
4GN□L	74%	89%						
5GU□L	74%	89%						
6GU□L	74%	89%						

ACCESSORIES

Motor • Gearhead bracket brackets

The dedicated mounting bracket is designed for easy installation and fixation of electric motors and reducers. It is a high-strength product suitable for large power electric motors and reducers.

The mounting bracket is pre-drilled with holes; please use the screws provided with the reducer to assemble the electric motor and reducer together. When installing the electric motor alone, please use separate mounting screws.



Motor frame size: 80mm

Model: HY4M5 Weight: 200g Material: Aluminum

Applicable products: 4GN Gearhead

Motor with the frame size of □80mm

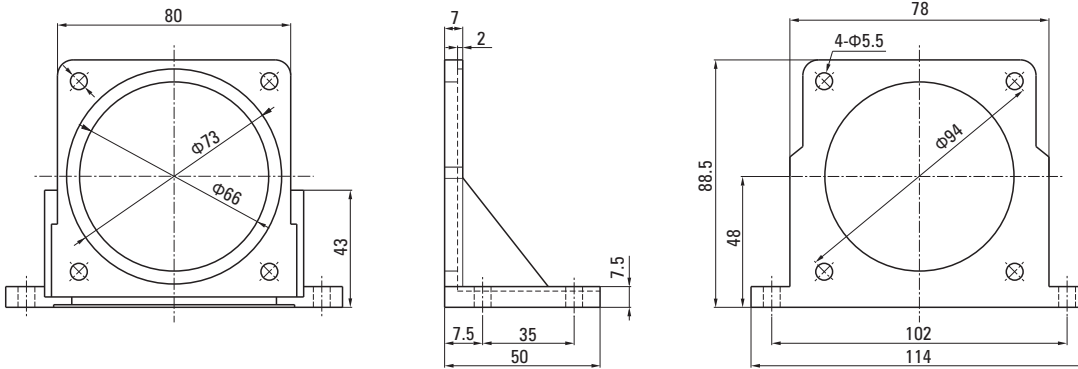

Motor frame size: 90mm

Model: HY5M5 Weight: 270g Material: Aluminum

Applicable products: 5GN, 5GU Gearhead

Motor with the frame size of □90mm

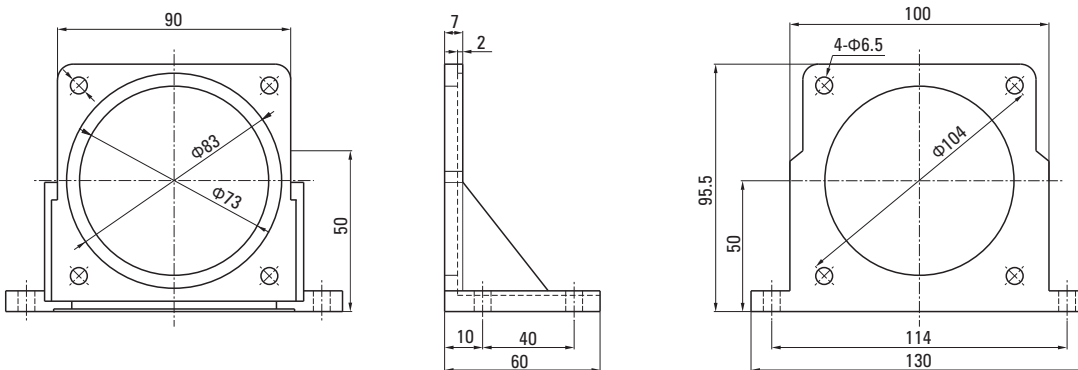



DC BRUSHLESS GEAR MOTOR CATALOGUE

Deputy Procurement Manager:Ming
Tel: +(86)18067150331
E-mail: info@hy-motor.com
Web: www.hy-motor.com

NINGBO HENGYAO TRADING CO.,LTD.
Add: No. 7, Qianzhai Road, Cixi City, Ningbo City, Zhejiang Province.