

HIGH PRECISION PLANETARY GEAR BOX

AE/AEW/AF/AFW/HBF/HBFW Series



AE/AF SERIES GEAR BOX

Sectional drawing

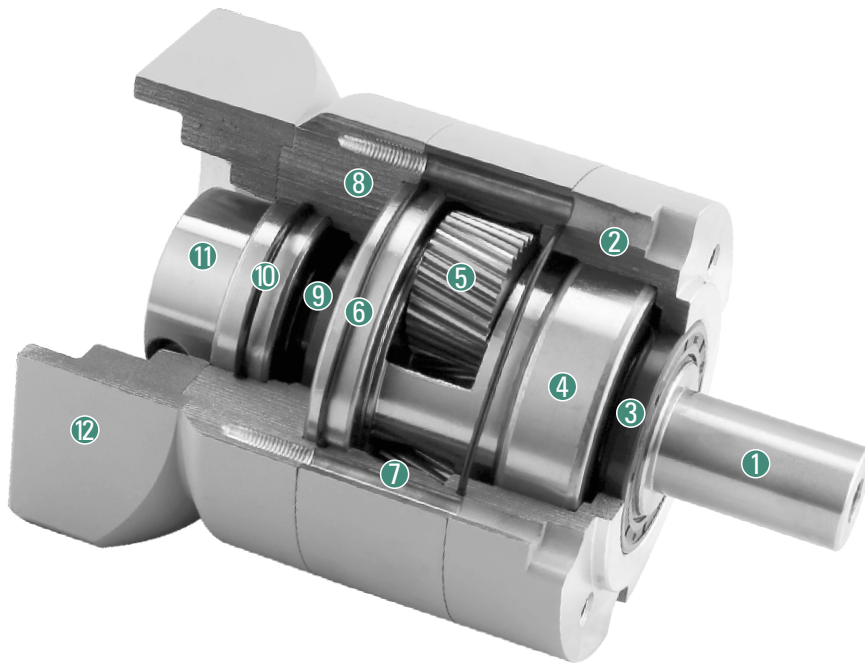

- ① Output shaft
- ② Front cover
- ③ Oil seal
- ④ Output shaft front bearing
- ⑤ Planetary gear
- ⑥ Output shaft rear bearing
- ⑦ Front cover
- ⑧ Rear cover
- ⑨ Solar wheel
- ⑩ Coupling
- ⑪ Coupling
- ⑫ Rear cover

Type and model number

AE/F Reducers					Servo motor	
60	AE/F	10	()	(S)	- 400	T1
①	②	③	④	⑤	⑥	⑦

① Gear head frame size: 060

Gear head series code:

- ② AE: Round mounting flange series
- AF: Square mounting flange series

③ Gear ratio: Single stage 10

- ④ Accuracy
- Output shaft load value at $\pm 3\%$ of allowable output torque

	Cabin seat	Stage	Standard (omitted)
60AE/F		1	7
		2	10
90AE/F		1	7
		2	10
120AE/F		1	7
		2	10
160AE/F		1	7
		2	10

Input shaft type

S: Overall locking (Omitted) (Can be used regardless of whether the motor has a keyway)

S1: Locking with locking ring (Can be used regardless of whether the motor has a keyway)

S2: Lock with keyway (Input shaft with key)

K: With keyway

A: Other adapters (Please contact us)

⑥ Applicable servo motor power (W)

⑦ Corresponding dimension table of input flange and servo motor ()

AE/AF PLANETARY GEAR BOX

Product diagram



Technical information

Product type		60	90	120	160	Reduction ratio	Series	
Rated output torque	N.M	31	85	144	342	3	1	
		50	95	200	542	4		
		41	105	220	650	5		
		30	93	200	550	7		
		23	83	180	500	8		
		18	70	155	450	10		
		31	115	209	-	12	2	
		31	115	209	342	15		
		50	130	275	-	16		
		50	130	275	542	20		
		41	135	280	650	25		
		50	120	260	-	32		
		41	125	265	550	35		
		41	115	245	500	40		
		41	135	280	650	50		
		23	83	180	-	64		
		23	83	180	500	80		
		18	73	165	450	100		
Life	Hour	20000						
Instant emergency stop torque	N.M	2 times rated output torque						

Product type	60	90	120	160	Unit	Series
Radial force	750	2100	2520	7000	N	-
Axial force	375	1050	1260	5000	N	-
Full load efficiency	≥ 97				%	1
	≥ 94					2
Weight	0.9	2.5	6.5	18	Kg	1
	1.2	3.0	7.2	20		2
Operating temperature	-10~+90				°C	-
Protection level	IP65					
Lubrication method	Lifetime lubrication					
Installation method	Any					

Maximum radial force and maximum axial force, when the output is 100RPM, it acts on the center position (L/2) of the output shaft.

AE/AF PLANETARY GEAR BOX

Technical information

Product type		60	90	120	160	Reduction ratio	Series
Moment of inertia	Kgcm ²	0.15	0.69	2.94	9.21	3	1
		0.12	0.50	2.27	7.54	4	
		0.10	0.46	2.10	7.42	5	
		0.10	0.42	2.00	7.14	7	
		0.10	0.42	2.00	7.07	8	
		0.09	0.39	1.90	7.03	10	
		0.06	0.32	1.50	-	12	2
		0.05	0.29	1.13	2.71	15	
		0.06	0.32	1.11	-	16	
		0.05	0.29	0.99	2.71	20	
		0.05	0.29	0.98	2.71	25	
		0.05	0.26	0.89	-	32	
		0.05	0.26	0.89	2.71	35	
		0.05	0.26	0.89	2.71	40	
		0.05	0.26	0.89	2.57	50	
		0.05	0.26	0.89	-	64	
		0.05	0.26	0.89	2.57	80	
		0.05	0.26	0.89	2.57	100	

Product type		60	90	120	160	Series
Backlash	arcmin	≤7	≤7	≤7	≤7	One series
		≤10	≤10	≤10	≤10	Two series
Torsion resistance	N.M/arcmin	1.8	4.5	12	38	-
Noise	dB(A)	63				-
Output speed	min ⁻¹	4500	4500	4500	4500	-
Recommended input speed	min ⁻¹	3000	3000	3000	3000	-

- Moment of inertia is related to input shaft.
- Noise detection standard, distance 1m, measured at input speed of 3000 rpm with no load.

AE PLANETARY GEAR BOX-MECHANICAL PARAMETER

Dimensional drawing

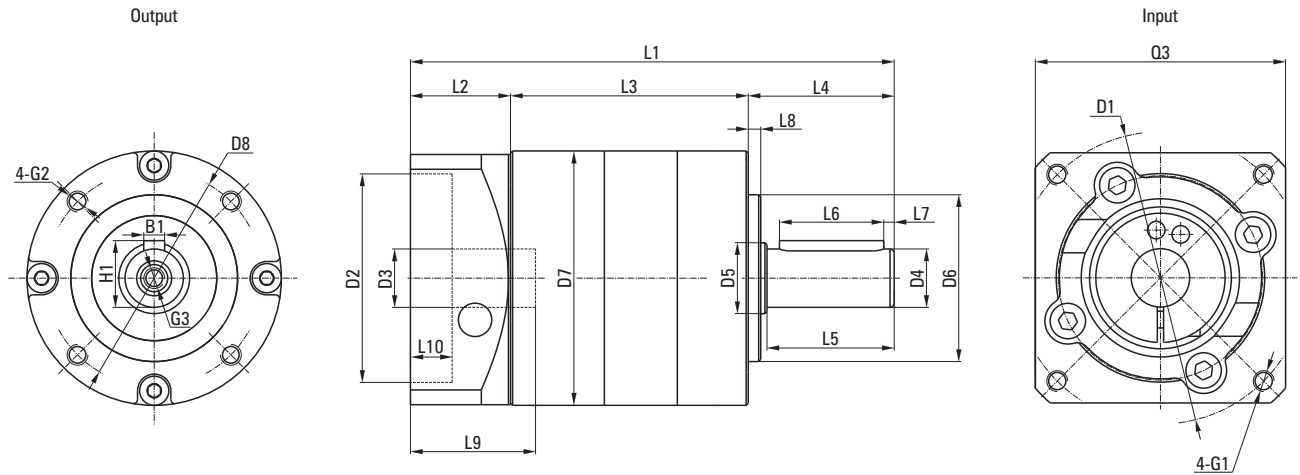

Dimensional table

[Unit: mm]

Product type	60AE		90AE		120AE		160AE	
Number of stage	1	2	1	2	1	2	1	2
L1 overall length	116	126	151	165.5	196	207	284.5	328.5
L3 body length	57	67	77.3	91.8	93	104	131.5	175.5
Output								
L4 output shaft length	35		40		55		87	
L5 output length to the shaft shoulder	30.5		36		50		80	
L6 key length	25		28		40		70	
L7 key length to shaft end	2.5		4		5		5	
L8 spigot length	3		3		4		5	
D4 output shaft diameter	Φ14h7		Φ20h7		Φ25h7		Φ40h7	
D5 shaft shoulder diameter	Φ20		Φ30		Φ40		Φ55	
D6 spigot length	Φ40h7		Φ60h7		Φ80h7		Φ130h7	
D7 body diameter	Φ61		Φ90		Φ115		Φ160	
D8 hole circle	Φ52		Φ70		Φ100		Φ145	
B1 key width	5		6		8		12	
H1 key height	16		22.5		28		43	
G2 mounting screw hole	M5X10		M6X12		M10X16		M12X20	
G3 center screw hole	M5X15		M6X18		M10X22		M12X25	
Input								
L2 input flange length	24		33.7		48		66	
L9 motor shaft length	30		40		58		79	
L10 spigot depth	10		10		10		10	
D1 mounting hole distribution circle	Φ70		Φ90		Φ145		Φ200	
D2 spigot diameter	Φ50G7		Φ70G7		Φ110G7		Φ114.3G7	
D3 input shaft diameter	≤14G7		≤19G7		≤24G7		≤35G7	
G1 mounting threads X depth	M4X10		M5X12		M8X21		M12X25	
Q3 input flange	□60		□80		□130		□175	

AF PLANETARY GEAR BOX-MECHANICAL PARAMETER

Dimensional drawing

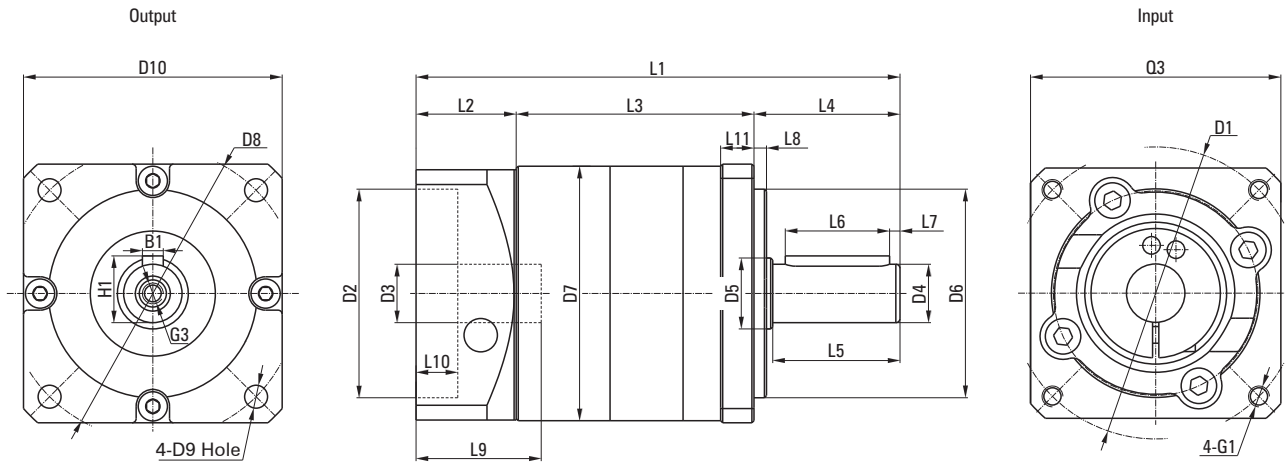

Dimensional table

[Unit: mm]

Product type	60AF		90AF		120AF		160AF	
Number of stage	1	2	1	2	1	2	1	2
L1 overall length	116	126	151	165.5	196	207	284.5	328.5
L3 body length	57	67	77.3	91.8	93	104	131.5	175.5
Output								
L4 output shaft length	35		40		55		87	
L5 output length to the shaft shoulder	30.5		36		50		80	
L6 key length	25		28		40		70	
L7 key length to shaft end	2.5		4		5		5	
L8 spigot length	3		3		4		5	
L11 output flange thickness	8		10		16		15	
D4 output shaft diameter	Φ14h7		Φ20h7		Φ25h7		Φ40h7	
D5 shaft shoulder diameter	Φ20		Φ30		Φ40		Φ55	
D6 spigot length	Φ50h7		Φ80h7		Φ110h7		Φ130h7	
D7 body diameter	Φ61		Φ90		Φ115		Φ160	
D8 hole circle	Φ70		Φ100		Φ130		Φ185/Φ200	
D9 mounting hole	Φ5.5		Φ6.5		Φ8.5		Φ11/Φ13.5	
D10 hole circle	□62		□90		□115		□160/□175	
B1 key width	5		6		8		12	
H1 key height	16		22.5		28		43	
G3 center screw hole	M5X15		M6X18		M10X22		M12X25	
Input								
L2 input flange length	24		33.7		48		66	
L9 motor shaft length	30		40		58		79	
L10 spigot depth	10		10		10		10	
D1 mounting hole distribution circle	Φ70		Φ90		Φ145		Φ200	
D2 spigot diameter	Φ50G7		Φ70G7		Φ110G7		Φ114.3G7	
D3 input shaft diameter	≤14G7		≤19G7		≤24G7		≤35G7	
G1 mounting threads X depth	M4X10		M5X12		M8X21		M12X25	
Q3 input flange	□60		□80		□130		□175	

HBF SERIES GEAR BOX

Sectional drawing

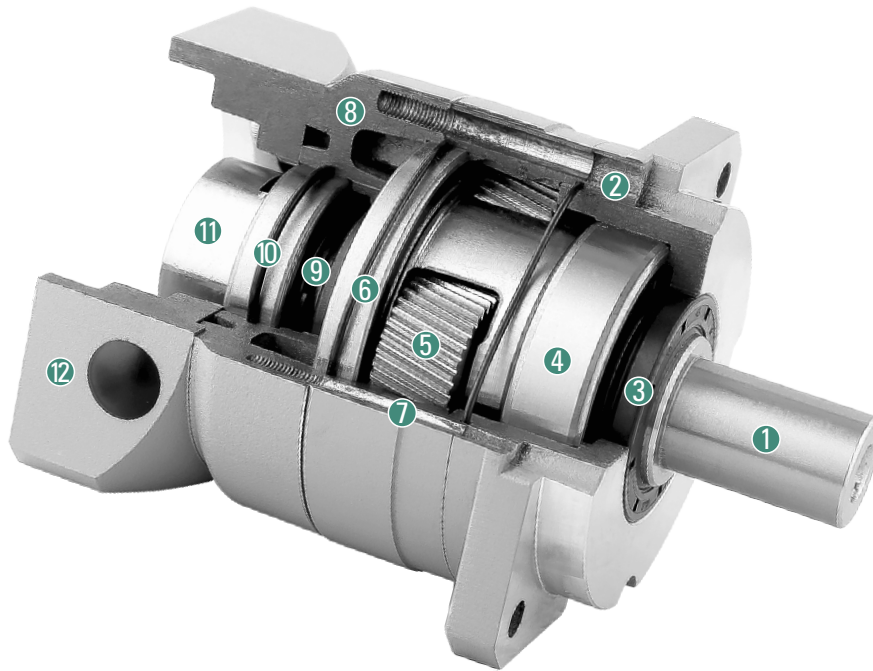

- ① Output shaft
- ② Front cover
- ③ Oil seal
- ④ Output shaft front bearing
- ⑤ Planetary gear
- ⑥ Output shaft rear bearing
- ⑦ Front cover
- ⑧ Rear cover
- ⑨ Solar wheel
- ⑩ Coupling
- ⑪ Coupling
- ⑫ Rear cover

Type and model number

HBF Reducers					Servo motor		
60	HBF	10	()	(S)	-	400	T1
①	②	③	④	⑤		⑥	⑦

①	Gear head frame size: 060/090/115/142/180					
②	Gear head series code: HBF: Square mounting flange					
③	Gear ratio: Single stage 10					
④	Accuracy Output shaft load value at $\pm 3\%$ of allowable output torque		Cabin seat	Stage	P1 Precise	P2 Standard
		060ZBF		1	3	5
				2	5	7
		090ZBF		1	3	5
				2	5	7
		115ZBF		1	3	5
				2	5	7
		142ZBF		1	3	5
				2	5	7
		180ZBF		1	3	5
	2		5	7		
Input shaft type						
S: Overall locking (Omitted) (Can be used regardless of whether the motor has a keyway)						
⑤	S1: Locking with locking ring (Can be used regardless of whether the motor has a keyway)					
	S2: Lock with keyway (Input shaft with key)					
	K: With keyway					
	A: Other adapters (Please contact us)					
⑥	Applicable servo motor power (W)					
⑦	Corresponding dimension table of input flange and servo motor ()					

HBF PLANETARY GEAR BOX

Product diagram

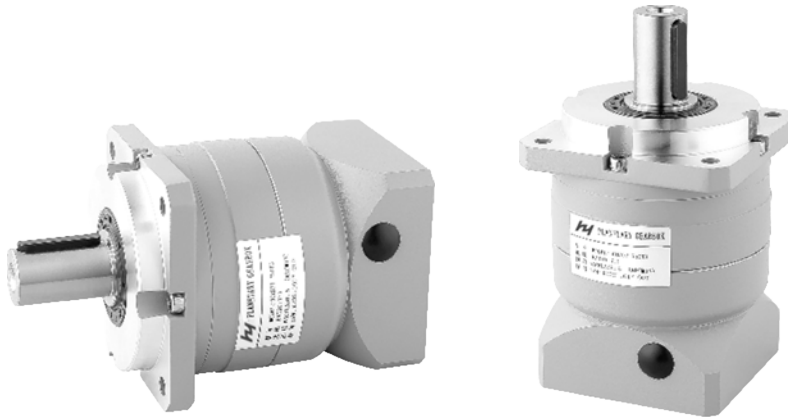

Technical information

Product type		060	090	115	142	180	Reduction ratio	Series
Rated output torque	N.M	45	120	198	332	578	3	1
		40	130	280	532	1040	4	
		50	150	320	650	1190	5	
		40	130	290	540	1090	7	
		35	110	250	490	990	8	
		30	90	220	440	890	10	2
		45	120	198	332	578	15	
		40	130	280	532	1040	20	
		50	150	320	640	1190	25	
		40	130	290	540	1190	35	
		35	110	250	490	990	40	
		50	150	320	640	1190	50	
		45	140	300	-	-	64	
		40	130	290	540	1090	70	
		35	110	250	490	990	80	
30	90	220	440	890	100			
Life	Hour	20000						
Instant emergency stop torque	N.M	3 times rated output torque						

Product type	060	090	115	142	180	Unit	Series
Radial force	1100	3000	6023	9230	13500	N	-
Axial force	630	1230	2550	4200	7000	N	-
Full load efficiency	≥ 97					%	1
							2
Weight	1.055	2.680	6.32	18.30	26.80	Kg	1
	1.065	3.135	7.20	22.14	33.55		2
Operating temperature	-10~+90					°C	-
Protection level	IP65						
Lubrication method	Lifetime lubrication						
Installation method	Any						

Maximum radial force and maximum axial force, when the output is 100RPM, it acts on the center position (L/2) of the output shaft.

HBF PLANETARY GEAR BOX

Technical information

Product type		060	090	115	142	180	Reduction ratio	Series
Moment of inertia	Kgcm ²	0.16	0.61	3.25	9.21	28.98	3	1
		0.14	0.48	2.74	7.54	23.67	4	
		0.13	0.47	2.71	7.42	23.29	5	
		0.13	0.45	2.62	7.14	22.48	7	
		0.13	0.44	2.58	7.07	22.59	8	
		0.13	0.44	2.57	7.03	22.51	10	
		0.03	0.13	0.47	2.71	7.42	15	2
		0.03	0.13	0.47	2.71	7.42	20	
		0.03	0.13	0.47	2.71	7.42	25	
		0.03	0.13	0.47	2.71	7.42	35	
		0.03	0.13	0.47	2.71	7.42	40	
		0.03	0.13	0.44	2.57	7.03	50	
		0.03	0.13	0.44	-	-	64	
		0.03	0.13	0.44	2.57	7.03	70	
		0.03	0.13	0.44	2.57	7.03	80	
		0.03	0.13	0.44	2.57	7.03	100	

Product type		60	90	115	142	180	Series
Backlash	arcmin	≤5	≤5	≤5	≤5	≤5	One series
		≤7	≤7	≤7	≤7	≤7	Two series
Torsion resistance	N.M/arcmin	7	14	25	50	145	-
Noise	dB(A)	≤63					-
Output speed	min ⁻¹	6000	6000	6000	6000	6000	-
Recommended input speed	min ⁻¹	3000	3000	3000	3000	3000	-

1. Moment of inertia is related to input shaft.
2. Noise detection standard, distance 1m, measured at input speed of 3000 rpm with no load.

HBF PLANETARY GEAR BOX-MECHANICAL PARAMETER

Dimensional drawing

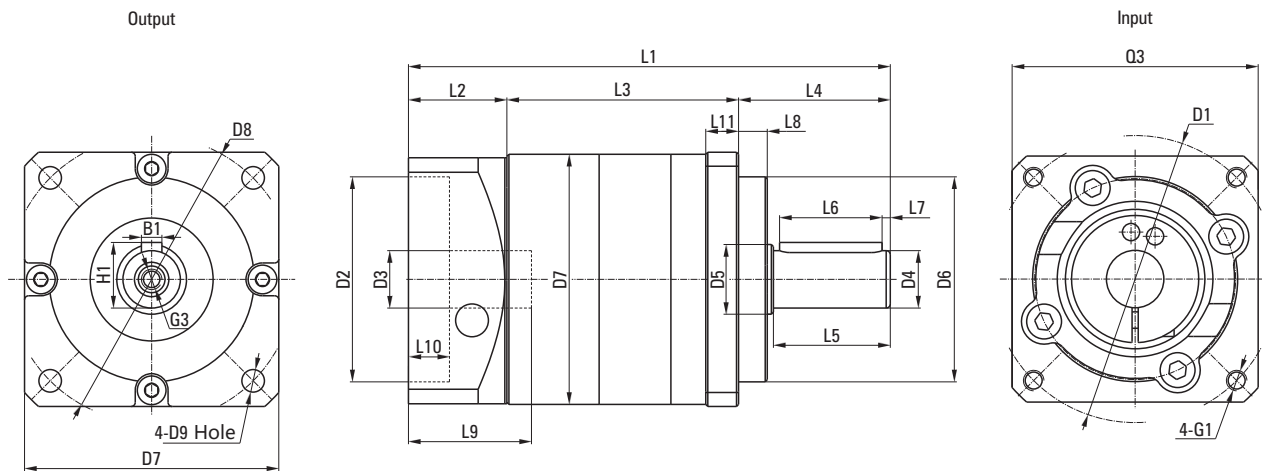

Dimensional table

[Unit: mm]

Product type	060ZBF		090ZBF		115ZBF		142ZBF		180ZBF	
Number of stage	1	2	1	2	1	2	1	2	1	2
L1 overall length	121.5	131.5	153	167.5	208	219	295.3	330.5	295.5	352.5
L3 body length	60.5	70.5	71.3	85.8	95	106	132.3	167.5	141	198
Output										
L4 output shaft length	37		48		65		97		105	
L5 output length to the shaft shoulder	28.5		36		51		79		82	
L6 key length	25		32		40		70		70	
L7 key length to shaft end	2		2		5		4		6	
L8 spigot length	7		10		12		15		20	
L11 output flange thickness	8		10		14		15		20	
D4 output shaft diameter	Φ16h7		Φ22h7		Φ32h7		Φ40h7		Φ55h7	
D5 shaft shoulder diameter	Φ20		Φ30		Φ40		Φ50		Φ65	
D6 spigot length	Φ50h7		Φ80h7		Φ110h7		Φ130h7		Φ160h7	
D7 body diameter	Φ61		Φ90		Φ115		Φ142		Φ180	
D8 hole circle	Φ70		Φ100		Φ130		Φ165		Φ215	
D9 mounting hole	Φ5.5		Φ6.5		Φ8.5		Φ11		Φ13	
D10 mounting width	□62		□90		□120		□142		□180	
B1 key width	5		6		10		12		16	
H1 key height	18		22.5		35		43		59	
G3 center screw hole	M5X15		M8X18		M12X28		M16X36		M20X42	
Input										
L2 input flange length	24		33.7		48		66		49.5	
L9 motor shaft length	30		40		58		81		81	
L10 spigot depth	10		10		10		12		12	
D1 mounting hole distribution circle	Φ70		Φ90		Φ145		Φ200		Φ200	
D2 spigot diameter	Φ50G7		Φ70G7		Φ110G7		Φ114.3G7		Φ114.3G7	
D3 input shaft diameter	≤Φ14G7		≤Φ19G7		≤Φ24G7		≤Φ35G7		≤Φ35G7	
G1 mounting threads X depth	M4X10		M5X12		M8X21		M12X28		M12X28	
Q3 input flange	□60		□80		□130		□176		□176	

HBFW/AE/FW SERIES GEAR BOX

Sectional drawing

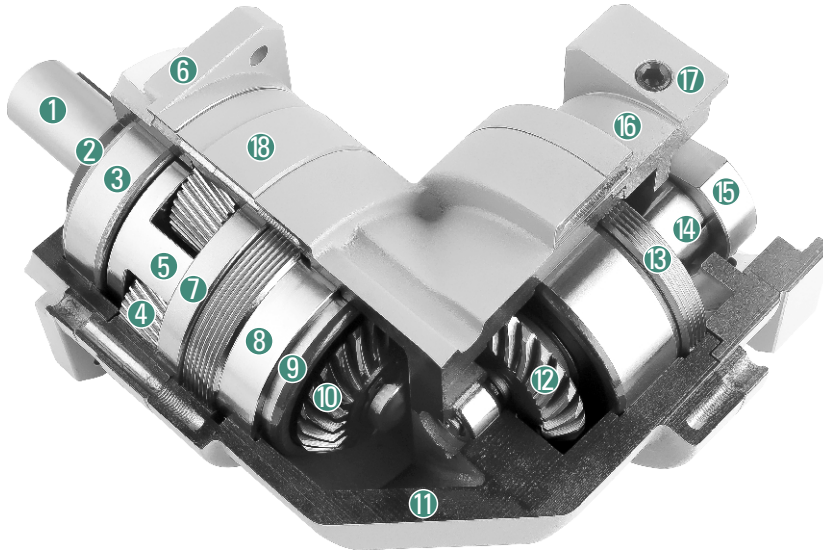

- ① Output shaft
- ② Oil seal
- ③ Output shaft front bearing
- ④ Planetary gear
- ⑤ Solar wheel
- ⑥ Front cover
- ⑦ Output shaft rear bearing
- ⑧ Adjusting nut
- ⑨ Double row angular contact bearing
- ⑩ Output bevel gear
- ⑪ Right angle box
- ⑫ Input bevel gear
- ⑬ Lock nut
- ⑭ Input coupling
- ⑮ Locking device
- ⑯ Rear cover
- ⑰ Rear cover gasket
- ⑱ Internal gear

Type and model number

HBFW Reducers	Servo motor
---------------	-------------

060
①
HBFW
②
10
③
()
④
(S)
⑤
-
400
⑥
T1
⑦

① Gear head frame size: 060/090/60/90

② Gear head series code:
HBFW: Square mounting flange

③ Gear ratio: Single stage 10

	Cabin seat	Stage	Standard (omitted)
④ Accuracy Output shaft load value at ±3% of allowable output torque	060ZBFW	1	8
		2	12
	090ZBFW	1	8
		2	12
	60AE/FW	1	10
		2	15
90AE/FW	1	10	
	2	15	

Input shaft type
 S: Overall locking (Omitted) (Can be used regardless of whether the motor has a keyway)
 S1: Locking with locking ring (Can be used regardless of whether the motor has a keyway)
 S2: Lock with keyway (Input shaft with key)
 K: With keyway
 A: Other adapters (Please contact us)

⑥ Applicable servo motor power (W)

⑦ Corresponding dimension table of input flange and servo motor ()

HBFW/AE/FW PLANETARY GEAR BOX

Product diagram

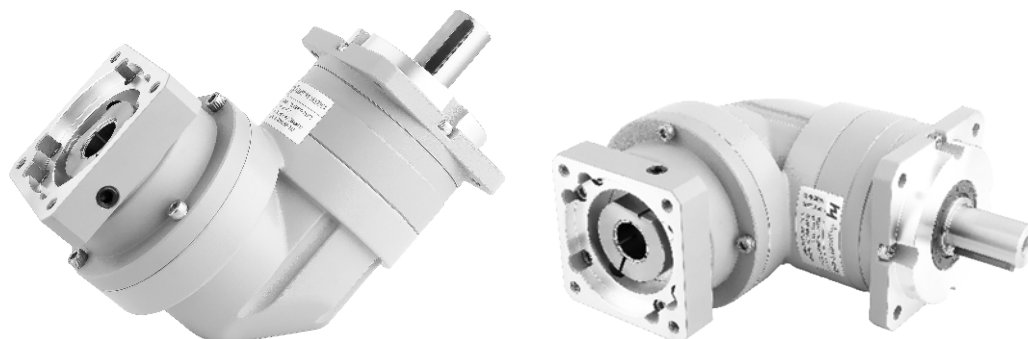

Technical information

Product type		060ZBFW	090ZBFW	60AE/FW	90AE/FW	Reduction ratio	Series
Rated output torque	N.M	45	120	31	85	3	1
		40	130	50	95	4	
		50	150	41	105	5	
		40	130	30	93	7	
		35	110	23	83	8	
		30	90	18	70	10	
		45	120	31	115	15	2
		40	130	50	130	20	
		50	150	41	135	25	
		40	150	41	125	35	
		35	150	41	115	40	
		50	150	41	135	50	
		45	110	23	83	64	
		40	120	30	110	70	
35	110	23	83	80			
30	90	18	73	100			
Life	Hour	20000					
Instant emergency stop torque	N.M	3 times rated output torque		2 times rated output torque			-

Product type	060ZBFW	090ZBFW	60AE/FW	90AE/FW	Unit	Series
Radial force	1100	3000	750	2100	N	-
Axial force	630	1230	375	1050	N	-
Full load efficiency	≥ 97				%	1
	≥ 94					2
Weight	1.6	5.6	1.5	5.6	Kg	1
	1.9	6.3	1.8	6.3		2
Operating temperature	-10~+90				°C	-
Protection level	IP65					
Lubrication method	Lifetime lubrication					
Installation method	Any					

Maximum radial force and maximum axial force, when the output is 100RPM, it acts on the center position (L/2) of the output shaft.

HBFW/AE/FW PLANETARY GEAR BOX

Technical information

Product type		060ZBFW	090ZBFW	60AE/FW	90AE/FW	Reduction ratio	Series
Moment of inertia	Kgcm ²	0.3	2.3	0.3	2.3	3	1
		0.3	2.3	0.3	2.3	4	
		0.3	2.3	0.3	2.3	5	
		0.3	2.3	0.3	2.3	7	
		0.3	2.3	0.3	2.3	8	
		0.3	2.3	0.3	2.3	10	
		0.07	0.3	0.07	0.3	15	2
		0.07	0.3	0.07	0.3	20	
		0.07	0.3	0.07	0.3	25	
		0.07	0.3	0.07	0.3	35	
		0.07	0.3	0.07	0.3	40	
		0.07	0.3	0.07	0.3	50	
		0.07	0.3	0.07	0.3	64	
		0.07	0.3	0.07	0.3	70	
		0.07	0.3	0.07	0.3	80	
		0.07	0.3	0.07	0.3	100	

Product type		060ZBFW	090ZBFW	60AE/FW	90AE/FW	Series
Backlash	arcmin	≤8	≤8	≤10	≤10	One series
		≤12	≤12	≤15	≤15	Two series
Torsion resistance	N.M/arcmin	7	14	1.8	4.5	-
Noise	dB(A)	≤65		≤73		-
Output speed	min ⁻¹	6000	6000	4500	4500	-
Recommended input speed	min ⁻¹	3000	3000	3000	3000	-

1. Moment of inertia is related to input shaft.
2. Noise detection standard, distance 1m, measured at input speed of 3000 rpm with no load.

HBFW/AFW PLANETARY GEAR BOX- MECHANICAL PARAMETER

Dimensional drawing

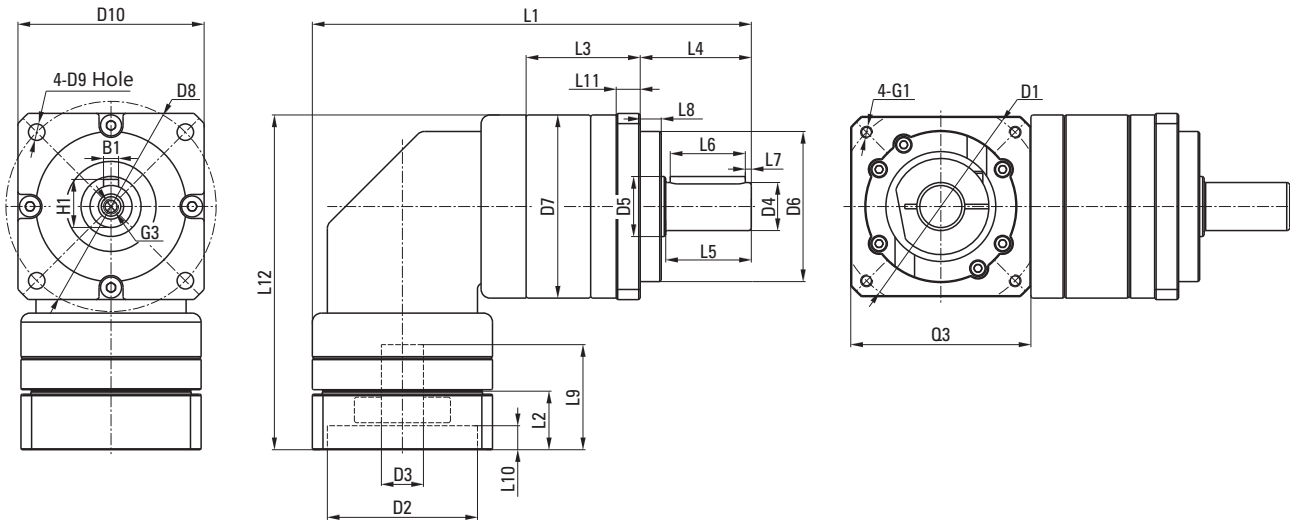

Dimensional table

[Unit: mm]

Product type	060ZBFW		090ZBFW		60AFW		90AFW	
Number of stage	1	2	1	2	1	2	1	2
L1 overall length	146.2	165.7	206.5	229.9	140.7	160.2	204.5	227.9
L3 body length	38	57.5	45.5	68.9	34.5	54	51.5	74.9
Output								
L4 output shaft length	37		48		35		40	
L5 output length to the shaft shoulder	28.5		36		30.5		36	
L6 key length	25		32		25		28	
L7 key length to shaft end	2		2		2.5		4	
L8 boss thickness	7		10		3		3	
L11 output flange thickness	8		10		8		10	
D4 output shaft diameter	Φ16h7		Φ22h7		Φ14h7		Φ20h7	
D5 shaft shoulder diameter	Φ20		Φ30		Φ20		Φ30	
D6 spigot length	Φ50h7		Φ80h7		Φ50h7		Φ80h7	
D7 body diameter	Φ61		Φ90		Φ61		Φ90	
D8 hole circle	Φ70		Φ100		Φ70		Φ100	
D9 mounting hole	Φ5.5		Φ6.5		Φ5.5		Φ6.5	
D10 mounting width	□62		□90		□62		□90	
B1 key width	5		6		5		6	
H1 key height	18		24.5		16		22.5	
G3 center screw hole	M5X15		M8X18		M5X15		M6X18	
Input								
L2 input flange length	19.5		20.5		19.5		20.5	
L9 motor shaft length	30		40		30		40	
L10 spigot depth	8		7		8		7	
D1 mounting hole distribution circle	Φ70		Φ90		Φ70		Φ90	
D2 spigot diameter	Φ50G7		Φ70G7		Φ50G7		Φ70G7	
D3 input shaft diameter	≤Φ14G7		≤Φ19G7		≤Φ14G7		≤Φ19G7	
G1 mounting threads X depth	M4X10		M5X12		M4X10		M5X12	
Q3 input flange	□60		□80		□60		□80	

AEW PLANETARY GEAR BOX-MECHANICAL PARAMETER

Dimensional drawing

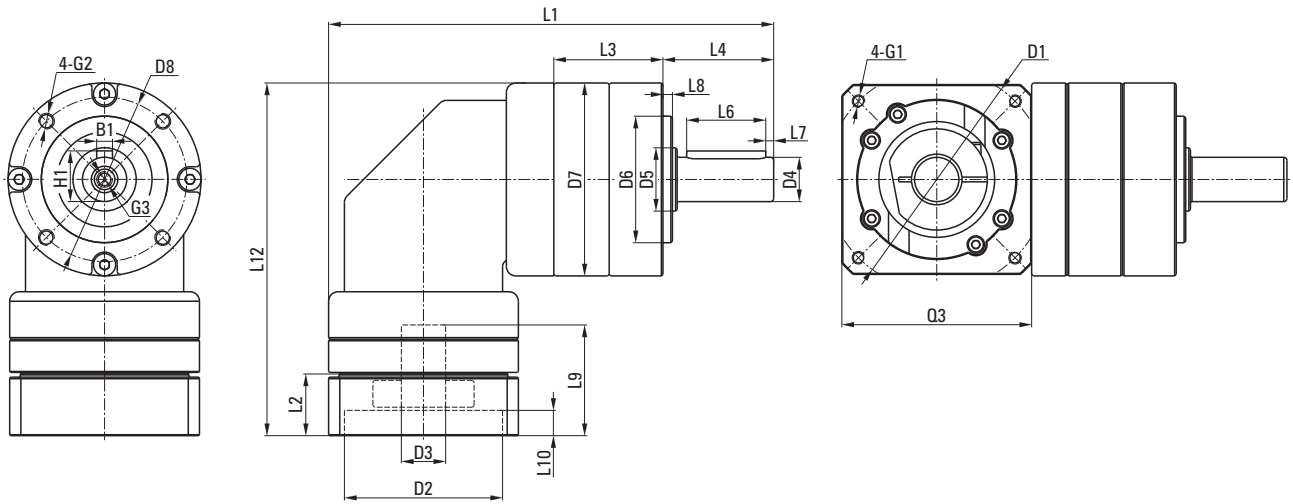

Dimensional table

[Unit: mm]

Product type	60AEW		90AEW	
	1	2	1	2
Number of stage	1	2	1	2
L1 overall length	140.7	160.2	204.5	227.9
L3 body length	34.5	54	51.5	74.9
Output				
L4 output shaft length	35		40	
L5 output length to the shaft shoulder	30.5		36	
L6 key length	25		28	
L7 key length to shaft end	2.5		4	
L8 boss thickness	3		3	
D4 output shaft diameter	Φ14h7		Φ20h7	
D5 shaft shoulder diameter	Φ20		Φ30	
D6 spigot length	Φ40h7		Φ60h7	
D7 body diameter	Φ61		Φ90	
D8 hole circle	Φ52		Φ70	
B1 key width	5		6	
H1 key height	16		22.5	
G2 mounting screw hole	M5X10		M6X12	
G3 center screw hole	M5X15		M6X18	
Input				
L2 input flange length	19.5		20.5	
L9 motor shaft length	30		40	
L10 spigot depth	8		7	
D1 mounting hole distribution circle	Φ70		Φ90	
D2 spigot diameter	Φ50G7		Φ70G7	
D3 input shaft diameter	≤Φ14G7		≤Φ19G7	
G1 mounting threads X depth	M4X10		M5X12	
Q3 input flange	□60		□80	

SERVO MOTOR CORRESPONDING SIZE TABLE

■ Gearbox input

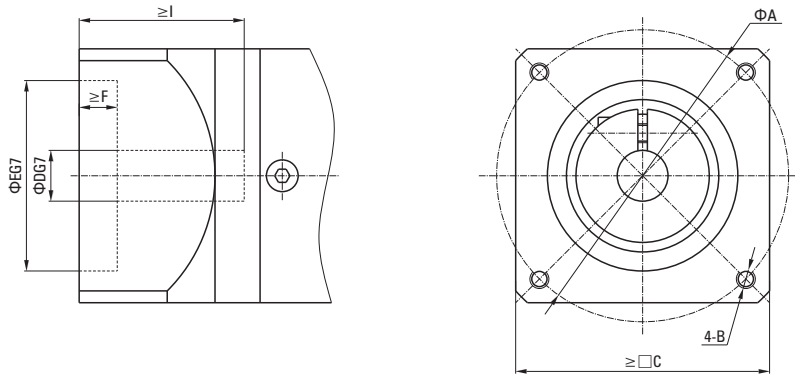

■ Input flange and servo motor matching table

Motor power (W)	Motor size	Installation distance	Threaded hole	Frame	Aperture	Stop	Stop depth	Shaft extension
		A	B	C	D	E	F	I
50	T1	45	M3	38	8	30	3	25
	T2	46	M4	40	6	30	3	25
	T3	47	M4	40	8	30	3	25
	T4	48	M3	42	8	30	3	25
100	T1	45	M3	38	8	30	3	25
	T2	46	M4	40	8	30	3	25
	T3	46	M4	40	8	30	3	25
	T4	48	M3	42	8	30	3	25
200	T1	70	M4	60	11	50	3	30
	T2	70	M5	60	14	50	3	30
	T3	70	M5	60	14	50	3	30
400	T1	70	M4	60	14	50	3	30
	T2	70	M5	60	14	50	3	30
	T3	70	M5	60	14	50	3	30
750	T1	90	M5	80	19	70	3	35
	T2	90	M6	80	16	70	3	40
	T3	90	M6	80	19	70	3	40
	T4	100	M6	86	16	80	3	35
	T5	145	M8	130	19	110	6	58
	T6	100	M6	86	19	80	3	40
1000	T1	100	M6	90	19	80	3	55
	T2	115	M6	100	24	95	3	45
	T3	115	M8	100	24	95	5	45
	T4	145	M8	130	22	110	6	58
	T5	145	M8	130	22	110	6	70
	T6	115	M8	100	22	95	5	45
	T7	145	M8	130	24	110	3	55
1500	T1	115	M8	100	19	95	3	55
	T2	115	M6	100	24	95	3	45
	T3	115	M8	100	24	95	3	45
	T4	145	M8	130	22	110	6	58
	T5	145	M8	130	22	110	6	70
	T6	115	M8	100	22	95	5	45
	T7	145	M8	130	24	110	3	55

SERVO MOTOR CORRESPONDING SIZE TABLE

Input flange and servo motor matching table

Motor power (W)	Motor size	Installation distance	Threaded hole	Frame	Aperture	Stop	Stop depth	Shaft extension
		A	B	C	D	E	F	I
2000	T1	115	M8	100	19	95	3	55
	T2	115	M6	100	24	95	3	45
	T3	115	M8	100	24	95	3	45
	T4	145	M8	130	22	110	6	58
	T5	200	M12	175	35	114.3	10	80
	T6	115	M8	100	22	95	5	45
2500	T1	115	M8	100	19	95	3	55
	T2	115	M6	100	24	95	3	45
3000	T1	130	M8	120	22	110	3	55
	T2	145	M8	130	28	110	6	65
	T4	145	M8	130	24	110	6	65
	T5	200	M12	175	35	114.3	10	80
	T7	200	M12	175	35	114.3	10	65
3500	T1	130	M8	120	22	110	3	55
	T2	145	M8	130	28	110	3	63
	T5	200	M12	175	35	114.3	10	80
4000	T1	145	M8	130	24	110	6	65
	T2	145	M8	130	28	110	6	65
	T5	200	M12	175	35	114.3	10	80
	T6	200	M12	175	42	114.3	10	113
4500	T1	145	M8	130	24	110	6	65
	T5	200	M12	175	35	114.3	10	80
	T6	200	M12	175	42	114.3	10	113
	T7	200	M12	175	35	114.3	10	65
5000	T1	145	M8	130	24	110	6	65
	T2	145	M8	130	28	110	6	65
	T5	200	M12	175	35	114.3	10	80
	T7	200	M12	175	35	114.3	10	65

1) If an oil-seal is not present and the size is different, attachment of the oil-seal may correspond to special order, in some cases.

2) If the motor shaft is of D-cut and taper type, it corresponds to a special order.

3) Out-of-standard may correspond to a special order in some cases, For details, contact us.

Assembly procedure

If a customer personally assembles the servo motor and reducer please use the following tip. The reducer flange to which the servo motor is attached has different dimensions based on the motor specified. Therefore, assembly may be impossible for some motor. Make sure the correct motor is specified before ordering the reducer.

1. Spec. in case of assembling a motor without key

- ① Take off the rubber cap, turn the input shaft, and match the head of the bolt to the hole of the rubber cap. Make sure that the set bolt is loosened.
- ② Gradually put the motor shaft into the input shaft (Ensure that it is smoothly put in without iam). Be careful not to be inserted with the motor tilted.
- ③ Attach the motor to the reducer and fasten the bolt with designated fastening torque. See table 1.
- ④ Fasten the set bolt of the input shaft with designated fastening torque wrench, etc. See table 2.
- ⑤ Put on the rubber cap. It is the end of assembling.

● Table1

Motor combination bolt	Fastening torque	
	(N-m)	(kgf-cm)
M3	1.0	10
M4	3.0	30
M5	5.8	60
M6	9.8	100
M8	19.6	200
M10	39.2	400
M12	68.6	700
M16	168	1650

● Table2

Combination bolt	Fastening torque	
	(N-m)	(kgf-cm)
M3	1.5	15
M4	3.5	35
M5	7.1	71
M6	12	120
M8	30	300
M10	60	612

You can assemble the motor with keyway like above when take off the key. There is no risk of dislocation.

● AE/AF series schematic diagram

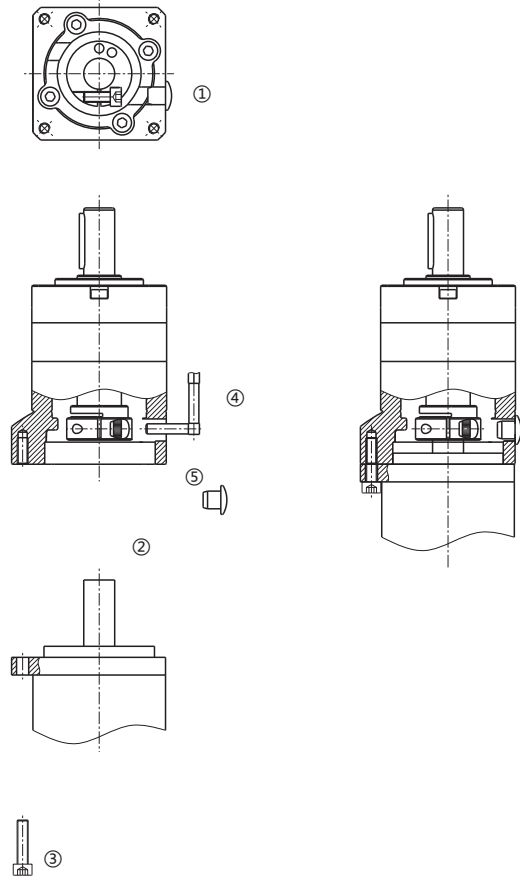

Reducer assembly

Jointing with reducer In case of jointing a reducer with the device, make sure that the combining side is plane without inconsistency, and when assemble reducer outo equipment, ensuring assembly surface smooth and without burr. See table 4.

● Table 4

Reducer combination bolt	Fastening torque	
	(N·m)	(kgf·cm)
M5	5.8	60
M6	9.8	100
M8	19.6	200
M10	39.2	400
M12	68.6	700
M16	16.8	1650

Connection to the output shaft

Cautions:

- 1、 When assemble a coupling, pulley, etc. onto the output shaft, make sure that excessive axial load not be given to the output shaft.
- 2、 In case of strongly hitting the shaft with a hammer, the shaft inlet or the inside of the reducer may be damaged, therefore it shall be prohibited.
- 3、 If the shaft or key of a coupling assembled is loosed, it may cause carbonization, so be careful when assembling.
- 4、 For assembling of a coupling, fix the key with a set bolt.
- 5、 Please adjust shaft centre carefully in connecting.

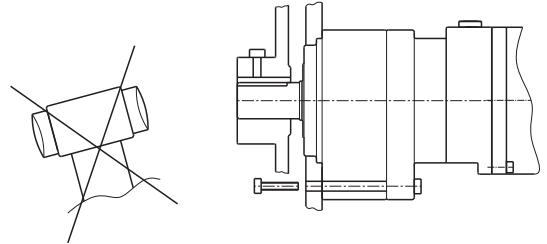



HIGH PRECISION PLANETARY GEAR BOX CATALOGUE

Deputy Procurement Manager:Ming
Tel: +(86)18067150331
E-mail: info@hy-motor.com
Web: www.hy-motor.com

NINGBO HENGYAO TRADING CO.,LTD.
Add: No. 7, Qianzhai Road, Cixi City, Ningbo City, Zhejiang Province.